

# 2 Trigonometry

## BUILDING ON

- applying the Pythagorean Theorem
- solving problems using properties of similar polygons
- solving problems involving ratios

## BIG IDEAS

In a right triangle,

- The ratio of any two sides remains constant even if the triangle is enlarged or reduced.
- You can use the ratio of the lengths of two sides to determine the measure of one of the acute angles.
- You can use the length of one side and the measure of an acute angle to determine the length of another side of the triangle.

## NEW VOCABULARY

angle of inclination

tangent ratio

indirect measurement

sine ratio

cosine ratio

angle of elevation

angle of depression



**SCIENCE WORLD** *This building was constructed for the Expo '86 World Fair held in Vancouver, British Columbia. The structure is a geodesic dome containing 766 triangles.*



# 2.1 The Tangent Ratio

## LESSON FOCUS

Develop the tangent ratio and relate it to the angle of inclination of a line segment.

*This ranger's cabin on Herschel Island, Yukon, has solar panels on its roof.*



## Make Connections

The **angle of inclination** of a line or line segment is the acute angle it makes with the horizontal.



South-facing solar panels on a roof work best when the **angle of inclination** of the roof, that is, the angle between the roof and the horizontal, is approximately equal to the latitude of the house.

When an architect designs a house that will have solar panels on its roof, she has to determine the width and height of the roof so that the panels work efficiently.

What happens to the angle of inclination if the diagram of the house is drawn using a different scale?

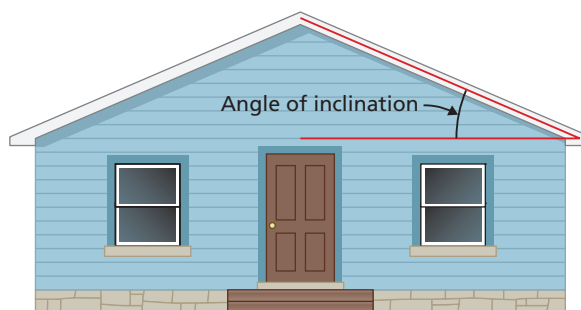

You will investigate the relationship between one acute angle in a right triangle and two sides of that triangle.

# Construct Understanding

Recall that two triangles are similar if one triangle is an enlargement or a reduction of the other.

## TRY THIS

Work with a partner.

You will need grid paper, a ruler, and a protractor.

- On grid paper, draw a right  $\triangle ABC$  with  $\angle B = 90^\circ$ .
- Each of you draws a different right triangle that is similar to  $\triangle ABC$ .
- Measure the sides and angles of each triangle. Label your diagrams with the measures.
- The two shorter sides of a right triangle are its legs. Calculate the ratio of the legs  $\frac{CB}{BA}$  as a decimal, then the corresponding ratio for each of the similar triangles.
- How do the ratios compare?
- What do you think the value of each ratio depends on?

We name the sides of a right triangle in relation to one of its acute angles.

The ratio

Length of side opposite  $\angle A$  : Length of side adjacent to  $\angle A$  depends only on the measure of the angle, not on how large or small the triangle is.

This ratio is called the **tangent ratio** of  $\angle A$ .

The tangent ratio for  $\angle A$  is written as  $\tan A$ .

We usually write the tangent ratio as a fraction.

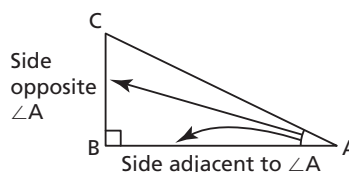

## The Tangent Ratio

If  $\angle A$  is an acute angle in a right triangle, then

$$\tan A = \frac{\text{length of side opposite } \angle A}{\text{length of side adjacent to } \angle A}$$

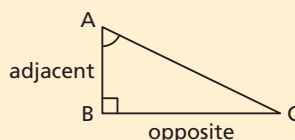

As the size of  $\angle A$  increases, what happens to  $\tan A$ ?

The value of the tangent ratio is usually expressed as a decimal that compares the lengths of the sides.

For example, if  $\tan A = 1.5$ ; then, in any similar right triangle with  $\angle A$ , the length of the side opposite  $\angle A$  is 1.5 times the length of the side adjacent to  $\angle A$ .

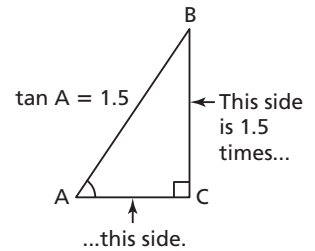

### Example 1 Determining the Tangent Ratios for Angles

Determine  $\tan D$  and  $\tan F$ .

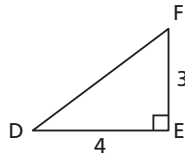

#### SOLUTION

$$\tan D = \frac{\text{length of side opposite } \angle D}{\text{length of side adjacent to } \angle D}$$

$$\tan D = \frac{EF}{DE} \quad \begin{array}{l} EF \text{ is opposite } \angle D, \\ DE \text{ is adjacent to } \angle D. \end{array}$$

$$\tan D = \frac{3}{4}$$

$$\tan D = 0.75$$

$$\tan F = \frac{\text{length of side opposite } \angle F}{\text{length of side adjacent to } \angle F}$$

$$\tan F = \frac{DE}{EF}$$

$$\tan F = \frac{4}{3}$$

$$\tan F = 1.\bar{3}$$

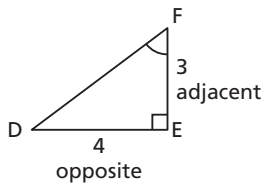
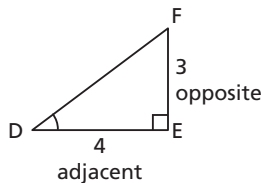

#### CHECK YOUR UNDERSTANDING

- Determine  $\tan X$  and  $\tan Z$ .

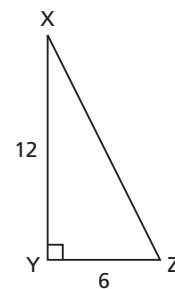

[Answer:  $\tan X = 0.5$ ;  $\tan Z = 2$ ]

How are the values of  $\tan D$  and  $\tan F$  related? Explain why this relation will always be true for the acute angles in a right triangle.

You can use a scientific calculator to determine the measure of an acute angle when you know the value of its tangent. The  $\tan^{-1}$  or InvTan calculator operation does this.

### Example 2 Using the Tangent Ratio to Determine the Measure of an Angle

Determine the measures of  $\angle G$  and  $\angle J$  to the nearest tenth of a degree.

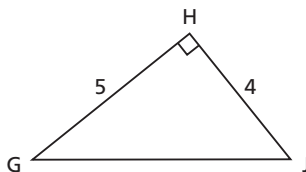

## SOLUTION

In right  $\triangle GHJ$ :

$$\tan G = \frac{\text{opposite}}{\text{adjacent}}$$

$$\tan G = \frac{HJ}{GH}$$

$$\tan G = \frac{4}{5}$$

$$\angle G \doteq 38.7^\circ$$

$$\tan J = \frac{\text{opposite}}{\text{adjacent}}$$

$$\tan J = \frac{GH}{HJ}$$

$$\tan J = \frac{5}{4}$$

$$\angle J \doteq 51.3^\circ$$

HJ is opposite  $\angle G$ , HG is adjacent to  $\angle G$ .

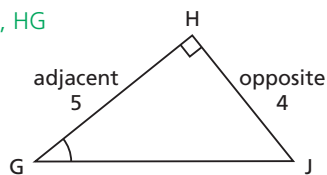

$$\tan^{-1}(0.8) \\ 38.65980825$$

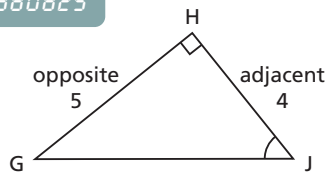

$$\tan^{-1}(1.25) \\ 51.34019175$$

## CHECK YOUR UNDERSTANDING

2. Determine the measures of  $\angle K$  and  $\angle N$  to the nearest tenth of a degree.

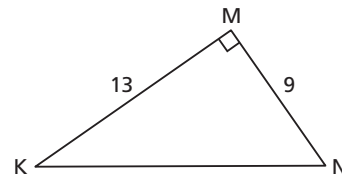

[Answer:  $\angle K \doteq 34.7^\circ$ ;  $\angle N \doteq 55.3^\circ$ ]

What other strategy could you use to determine  $\angle J$ ?

## Example 3 Using the Tangent Ratio to Determine an Angle of Inclination

The latitude of Fort Smith, NWT, is approximately  $60^\circ$ . Determine whether this design for a solar panel is the best for Fort Smith. Justify your answer.

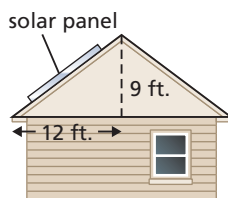

## SOLUTION

The best angle of inclination for the solar panel is the same as the latitude,  $60^\circ$ .

Draw a right triangle to represent the cross-section of the roof and solar panel.  $\angle C$  is the angle of inclination. In  $\triangle ABC$ :

$$\tan C = \frac{\text{opposite}}{\text{adjacent}}$$

$$\tan C = \frac{AB}{BC}$$

$$\tan C = \frac{9}{12}$$

$$\angle C \doteq 37^\circ$$

AB is opposite  $\angle C$ , BC is adjacent to  $\angle C$ .

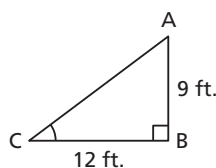

$$\tan^{-1}(0.75) \\ 36.86989765$$

The angle of inclination of the solar panel is about  $37^\circ$ , which is not equal to the latitude of Fort Smith. So, this is not the best design.

## CHECK YOUR UNDERSTANDING

3. Clyde River on Baffin Island, Nunavut, has a latitude of approximately  $70^\circ$ . The diagram shows the side view of some solar panels. Determine whether this design for solar panels is the best for Clyde River. Justify your answer.

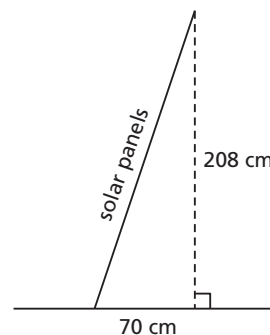

[Answer: The angle of inclination is approximately  $71^\circ$ . So, the design is the best.]

## Example 4 Using the Tangent Ratio to Solve a Problem

A 10-ft. ladder leans against the side of a building with its base 4 ft. from the wall.

What angle, to the nearest degree, does the ladder make with the ground?

### SOLUTION

Draw a diagram.

Assume the ground is horizontal and the building vertical.

Label the vertices of the triangle PQR.

To use the tangent ratio to determine  $\angle R$ , we first need to know the length of PQ.

Use the Pythagorean Theorem in right  $\triangle PQR$ .

$$PR^2 = PQ^2 + QR^2 \quad \text{Isolate the unknown.}$$

$$PQ^2 = PR^2 - QR^2$$

$$PQ^2 = 10^2 - 4^2$$

$$= 84$$

$$PQ = \sqrt{84}$$

Use the tangent ratio in right  $\triangle PQR$ .

$$\tan R = \frac{PQ}{QR} \quad \begin{array}{l} PQ \text{ is opposite } \angle R, \\ QR \text{ is adjacent to } \angle R. \end{array}$$

$$\tan R = \frac{\sqrt{84}}{4}$$

$$\tan R = 2.2913\dots$$

$$\angle R \doteq 66^\circ$$

The angle between the ladder and the ground is approximately  $66^\circ$ .

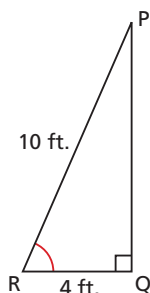

### CHECK YOUR UNDERSTANDING

4. A support cable is anchored to the ground 5 m from the base of a telephone pole. The cable is 19 m long. It is attached near the top of the pole. What angle, to the nearest degree, does the cable make with the ground?

[Answer: The angle is approximately  $75^\circ$ .]

Suppose you used  $PQ \doteq 9.2$ , instead of  $PQ = \sqrt{84}$ . How could this affect the calculated measure of  $\angle R$ ?

## Discuss the Ideas

1. Why does the value of the tangent ratio of a given angle not depend on the right triangle you use to calculate it?
2. How can you use the tangent ratio to determine the measures of the acute angles of a right triangle when you know the lengths of its legs?

# Exercises

## A

3. In each triangle, write the tangent ratio for each acute angle.

a)

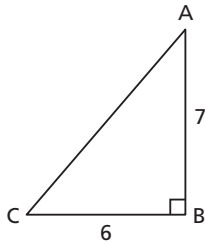

b)

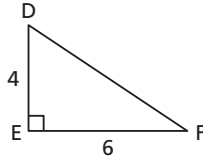

c)

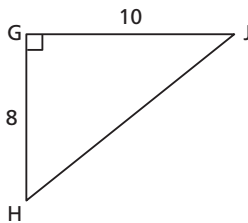

d)

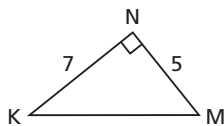

4. To the nearest degree, determine the measure of  $\angle X$  for each value of  $\tan X$ .

a)  $\tan X = 0.25$

b)  $\tan X = 1.25$

c)  $\tan X = 2.50$

d)  $\tan X = 20$

5. Determine the measure of each indicated angle to the nearest degree.

a)

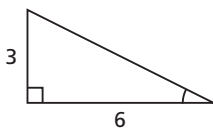

b)

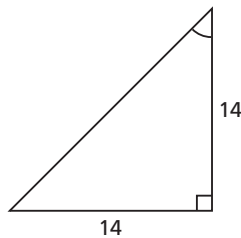

c)

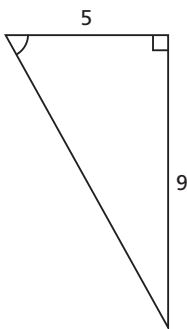

d)

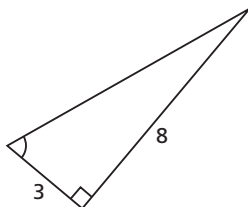

## B

6. Use grid paper. Illustrate each tangent ratio by sketching a right triangle, then labelling the measures of its legs.

a)  $\tan B = \frac{3}{5}$    b)  $\tan E = \frac{5}{3}$    c)  $\tan F = \frac{1}{4}$

d)  $\tan G = 4$    e)  $\tan H = 1$    f)  $\tan J = 25$

7. a) Is  $\tan 60^\circ$  greater than or less than 1? How do you know without using a calculator?  
 b) Is  $\tan 30^\circ$  greater than or less than 1? How do you know without using a calculator?

8. Determine the measure of each indicated angle to the nearest tenth of a degree. Describe your solution method.

a)

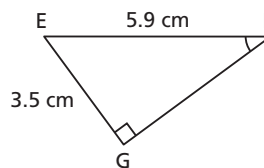

b)

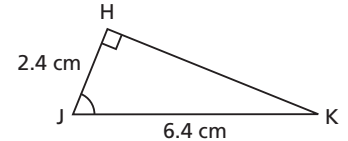

9. a) Why are these triangles similar?

i)

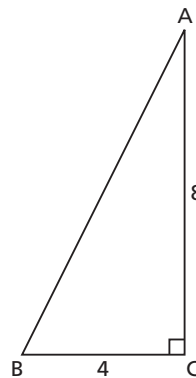

ii)

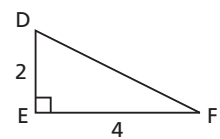

iii)

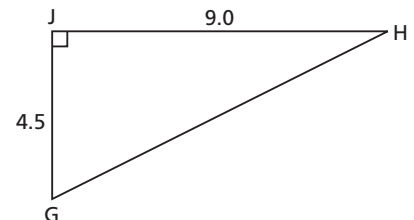

- b) For each triangle in part a, determine the measures of the acute angles to the nearest tenth of a degree.  
 c) To complete part b, did you have to calculate the measures of all 6 acute angles? Explain.



10. Determine the angle of inclination of each line to the nearest tenth of a degree.

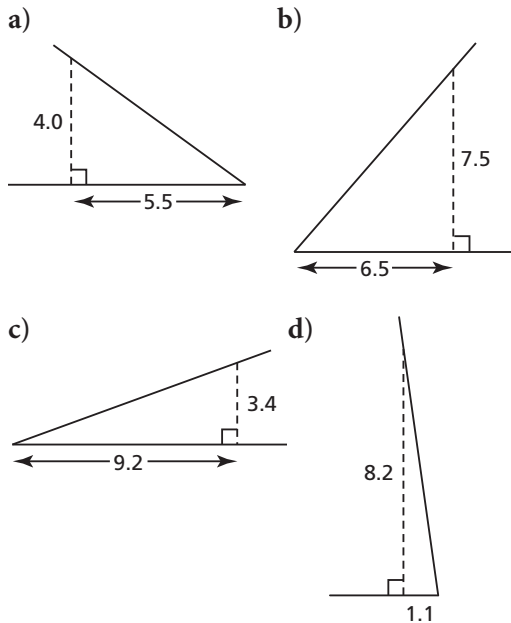

11. The grade or inclination of a road is often expressed as a percent. When a road has a grade of 20%, it increases 20 ft. in altitude for every 100 ft. of horizontal distance.

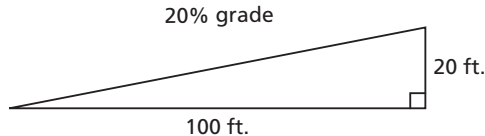

Calculate the angle of inclination, to the nearest degree, of a road with each grade.

- a) 20%   b) 25%   c) 10%   d) 15%

12. The approximate latitudes for several cities in western and northern Canada are shown.

Calgary	51.1°	Edmonton	53.5°
Fort McMurray	56.5°	Inuvik	68.4°
Kamloops	51.2°	Saskatoon	52.2°
Victoria	48.4°	Whitehorse	60.7°

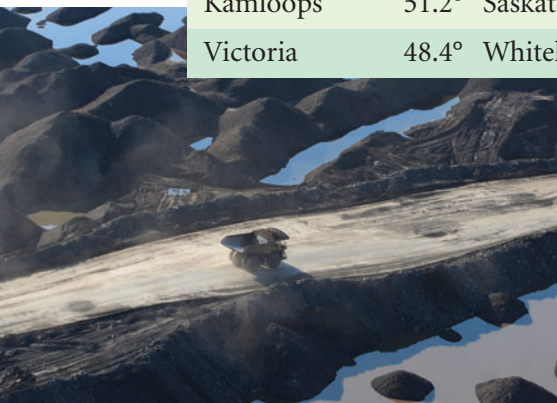

- For which locations might the following roof design be within  $1^\circ$  of the recommended angle for solar panels? Justify your answer.

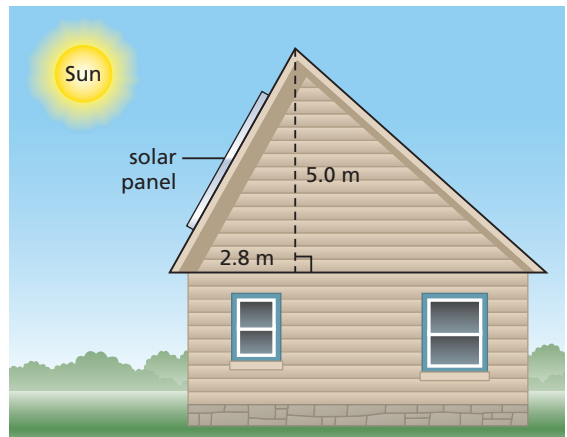

13. Determine the measures of all the acute angles in this diagram, to the nearest tenth of a degree.

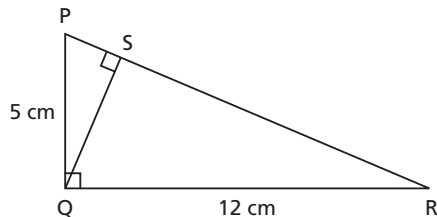

14. A birdwatcher sights an eagle at the top of a 20-m tree. The birdwatcher is lying on the ground 50 m from the tree. At what angle must he incline his camera to take a photograph of the eagle? Give the answer to the nearest degree.



15. A rectangle has dimensions 3 cm by 8 cm. What angles does a diagonal of the rectangle make with the sides of the rectangle? Give the measures to the nearest tenth of a degree.
16. In a right isosceles triangle, why is the tangent of an acute angle equal to 1?

17. A playground slide starts 107 cm above the ground and is 250 cm long. What angle does the slide make with the ground? Give the answer to the nearest degree.



18. The Pioneer ski lift at Golden, B.C., is 1366 m long. It rises 522 m vertically. What is the angle of inclination of the ski lift? Give the answer to the nearest degree.
19. From a rectangular board, a carpenter cuts a stringer to support some stairs. Each stair rises 7.5 in. and has a tread of 11.0 in. To the nearest degree, at what angle should the carpenter cut the board?

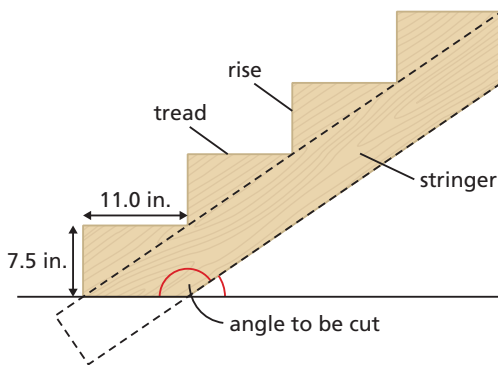

20. For safety reasons, a ladder is positioned so that the distance between its base and the wall is no greater than  $\frac{1}{4}$  the length of the ladder. To the nearest degree, what is the greatest angle of inclination allowed for a ladder?

C

21. In isosceles  $\triangle XYZ$ ,  $XY = XZ = 5.9$  cm and  $YZ = 5.0$  cm. Determine the measures of the angles of the triangle to the nearest tenth of a degree.
22. For the tangent of an acute angle in a right triangle:  
 a) What is the least possible value?  
 b) What is the greatest possible value?  
 Justify your answers.
23. A Pythagorean spiral is constructed by drawing right triangles on the hypotenuse of other right triangles. Start with a right triangle in which each leg is 1 unit long. Use the hypotenuse of that triangle as one leg of a new triangle and draw the other leg 1 unit long. Continue the process. A spiral is formed.

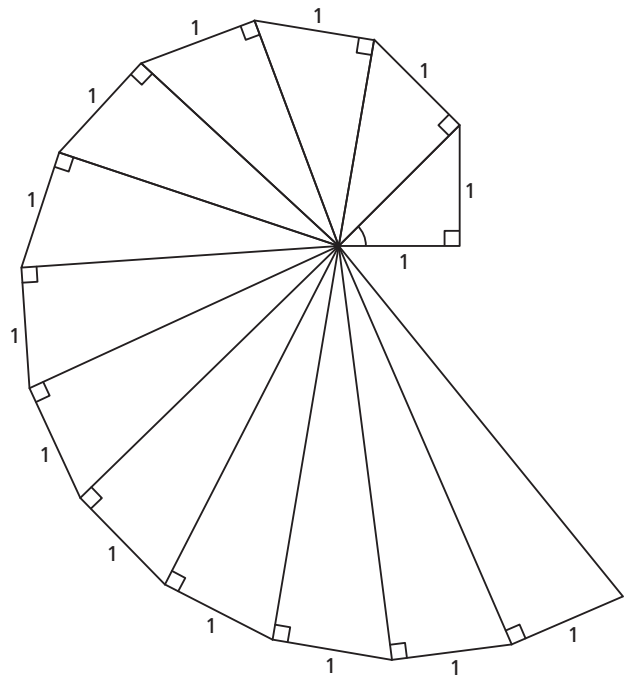

- a) Determine the tangent of the angle at the centre of the spiral in each of the first 5 triangles.
- b) Use the pattern in part a) to predict the tangent of the angle at the centre of the spiral for the 100th triangle. Justify your answer.

Reflect

Summarize what you have learned about the tangent ratio and its relationship to the sides and angles of a right triangle.

## 2.2 Using the Tangent Ratio to Calculate Lengths

### LESSON FOCUS

Apply the tangent ratio to calculate lengths.

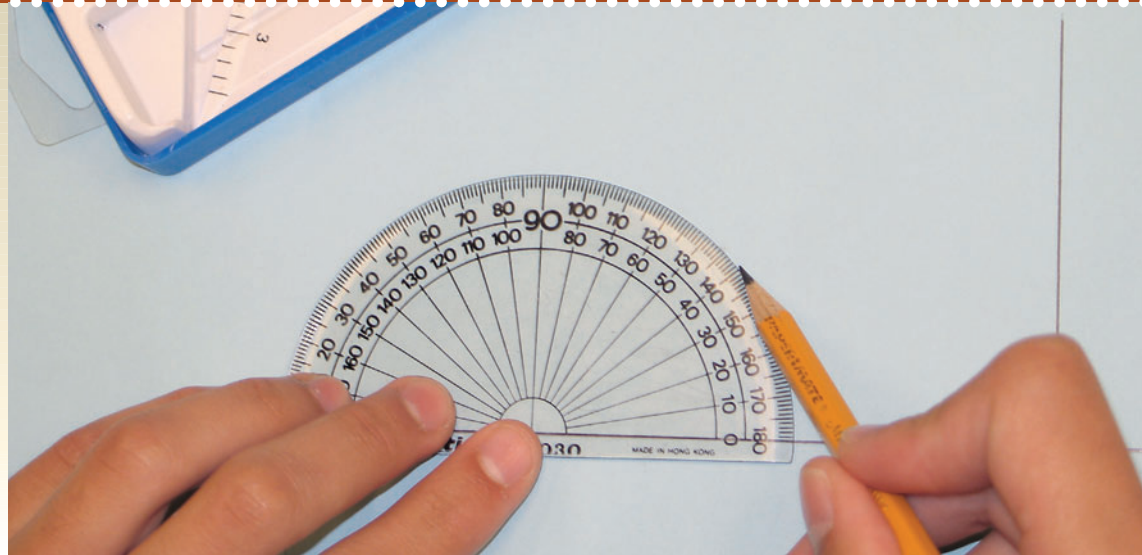

### Make Connections

In Lesson 2.1, you used the measures of two legs of a right triangle to calculate the measures of the acute angles of the triangle. When you know the length of one leg of a right triangle and the measure of one acute angle, you can draw the triangle.

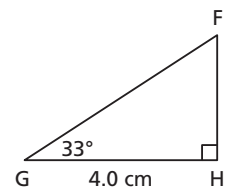

What other measures in the triangle can you calculate?

### Construct Understanding

#### THINK ABOUT IT

Work with a partner.

In right  $\triangle PQR$ ,  $\angle Q = 90^\circ$ ,  $\angle P = 34.5^\circ$ , and  $PQ = 46.1$  cm.  
Determine the length of  $RQ$  to the nearest tenth of a centimetre.

We use **direct measurement** when we use a measuring instrument to determine a length or an angle in a polygon. We use **indirect measurement** when we use mathematical reasoning to calculate a length or an angle.

The tangent ratio is a powerful tool we can use to calculate the length of a leg of a right triangle. We are then measuring the length of a side of a triangle **indirectly**.

In a right triangle, we can use the tangent ratio,  $\frac{\text{opposite}}{\text{adjacent}}$ , to write an equation.

When we know the measure of an acute angle and the length of a leg, we solve the equation to determine the length of the other leg.

## Example 1 Determining the Length of a Side Opposite a Given Angle

Determine the length of AB to the nearest tenth of a centimetre.

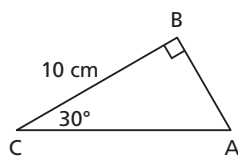

### SOLUTION

In right  $\triangle ABC$ , AB is the side opposite  $\angle C$  and BC is the side adjacent to  $\angle C$ .

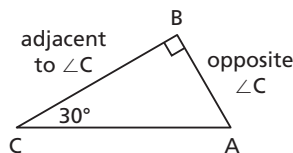

Use the tangent ratio to write an equation.

$$\tan C = \frac{\text{opposite}}{\text{adjacent}}$$

$$\tan C = \frac{AB}{BC}$$

$$\tan 30^\circ = \frac{AB}{10}$$

Solve this equation for AB.

$$10 \times \tan 30^\circ = \frac{AB}{10} \times 10$$

$$10 \tan 30^\circ = AB$$

$$AB = 5.7735\dots$$

AB is approximately 5.8 cm long.

Multiply both sides by 10.

We write:  $10 \times \tan 30^\circ$  as  $10 \tan 30^\circ$   
When an operation sign is omitted, it is understood to be multiplication.

### CHECK YOUR UNDERSTANDING

- Determine the length of XY to the nearest tenth of a centimetre.

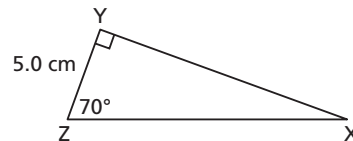

[Answer:  $XY \approx 13.7$  cm]

How can you determine the length of the hypotenuse in  $\triangle ABC$ ?

## Example 2 Determining the Length of a Side Adjacent to a Given Angle

Determine the length of EF to the nearest tenth of a centimetre.

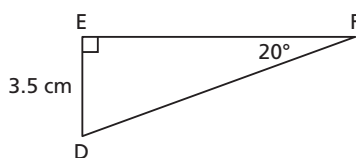

### SOLUTIONS

#### Method 1

In right  $\triangle DEF$ , DE is opposite  $\angle F$  and EF is adjacent to  $\angle F$ .

$$\tan F = \frac{\text{opposite}}{\text{adjacent}}$$

(Solution continues.)

### CHECK YOUR UNDERSTANDING

- Determine the length of VX to the nearest tenth of a centimetre.

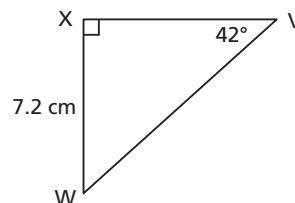

[Answer:  $VX \approx 8.0$  cm]

$$\tan F = \frac{DE}{EF}$$

$$\tan 20^\circ = \frac{3.5}{EF}$$

Solve the equation for EF.

Multiply both sides by EF.

$$EF \tan 20^\circ = EF \left( \frac{3.5}{EF} \right)$$

$$EF \tan 20^\circ = 3.5$$

Divide both sides by  $\tan 20^\circ$ .

$$\frac{EF \tan 20^\circ}{\tan 20^\circ} = \frac{3.5}{\tan 20^\circ}$$

$$EF = \frac{3.5}{\tan 20^\circ}$$

$$EF = 9.6161\dots$$

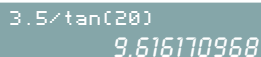

EF is approximately 9.6 cm long.

### Method 2

In right  $\triangle DEF$ :

$$\angle D + \angle F = 90^\circ$$

$$\angle D + 20^\circ = 90^\circ$$

$$\angle D = 90^\circ - 20^\circ$$

$$\angle D = 70^\circ$$

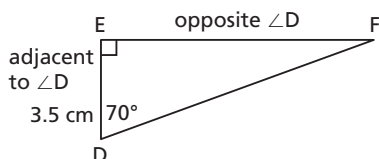

EF is opposite  $\angle D$  and DE is adjacent to  $\angle D$ .

$$\tan D = \frac{\text{opposite}}{\text{adjacent}}$$

$$\tan D = \frac{EF}{DE}$$

$$\tan 70^\circ = \frac{EF}{3.5}$$

Solve the equation for EF.

Multiply both sides by 3.5.

$$3.5 \tan 70^\circ = \frac{(EF)(3.5)}{3.5}$$

$$3.5 \tan 70^\circ = EF$$

$$EF = 9.6161\dots$$

EF is approximately 9.6 cm long.

What is the advantage of solving the equation for EF before calculating  $\tan 20^\circ$ ?

Which method to determine EF do you think is easier? Why?

How could you determine the length of DF?

It is often convenient to use the lower case letter to name the side opposite a vertex of a triangle.

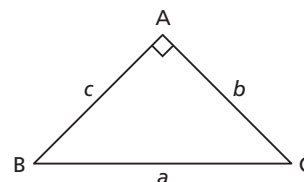

## Example 3 Using Tangent to Solve an Indirect Measurement Problem

A searchlight beam shines vertically on a cloud. At a horizontal distance of 250 m from the searchlight, the angle between the ground and the line of sight to the cloud is  $75^\circ$ . Determine the height of the cloud to the nearest metre.

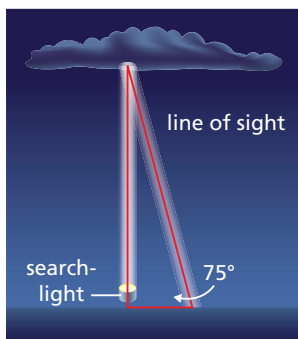

### SOLUTION

Sketch and label a diagram to represent the information in the problem.

Assume the ground is horizontal.

In right  $\triangle CSP$ , side  $CS$  is opposite  $\angle P$  and  $SP$  is adjacent to  $\angle P$ .

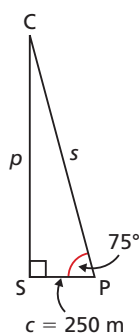

$$\tan P = \frac{\text{opposite}}{\text{adjacent}}$$

$$\tan P = \frac{p}{c}$$

$$\tan 75^\circ = \frac{p}{250}$$

Solve the equation for  $p$ . Multiply both sides by 250.

$$250 \tan 75^\circ = \left(\frac{p}{250}\right)250$$

$$250 \tan 75^\circ = p$$

$$p = 933.0127\dots$$

The cloud is approximately 933 m high.

### CHECK YOUR UNDERSTANDING

3. At a horizontal distance of 200 m from the base of an observation tower, the angle between the ground and the line of sight to the top of the tower is  $8^\circ$ . How high is the tower to the nearest metre? The diagram is *not* drawn to scale.

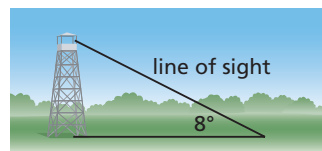

[Answer: 28 m]

Why can we draw a right triangle to represent the problem?

### Discuss the Ideas

1. How can you use the tangent ratio to determine the length of a leg in a right triangle?
2. Suppose you know or can calculate the lengths of the legs in a right triangle. Why can you always calculate its hypotenuse?

# Exercises

## A

3. Determine the length of each indicated side to the nearest tenth of a centimetre.

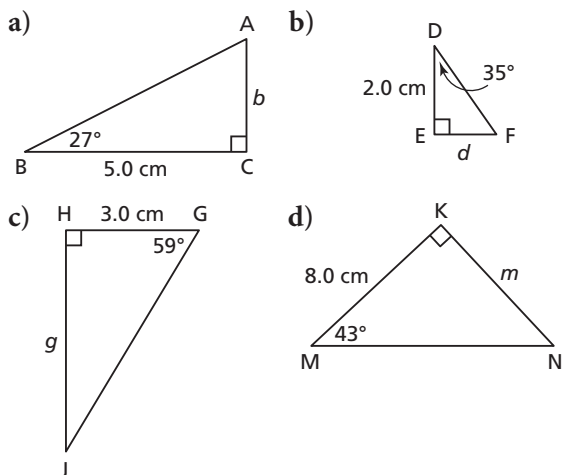

4. Determine the length of each indicated side to the nearest tenth of a centimetre.

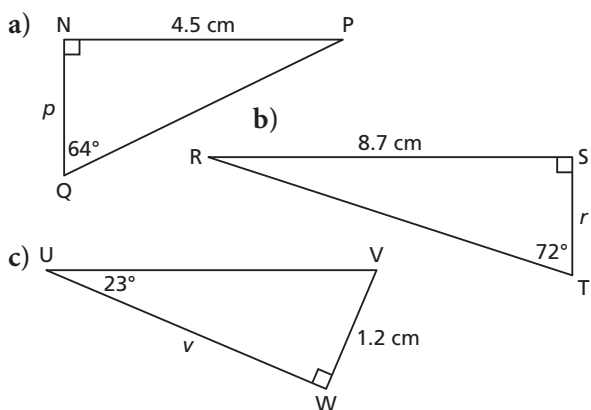

5. Determine the length of each indicated side to the nearest tenth of a centimetre.

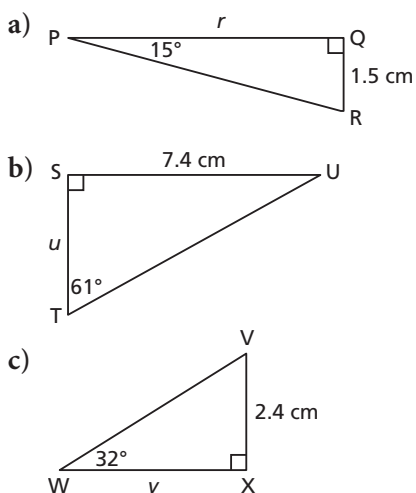

## B

6. A guy wire helps to support a tower. The angle between the wire and the level ground is  $56^\circ$ . One end of the wire is 15.4 m from the base of the tower. How high up the tower does the wire reach to the nearest tenth of a metre?

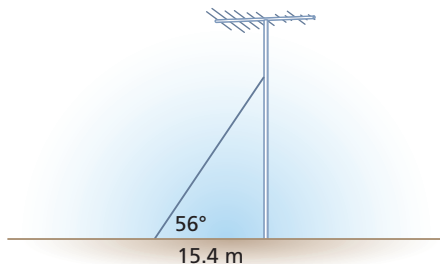

7. The base of a ladder is on level ground 1.3 m from a wall. The ladder leans against the wall. The angle between the ladder and the ground is  $71^\circ$ . How far up the wall does the ladder reach to the nearest tenth of a metre?

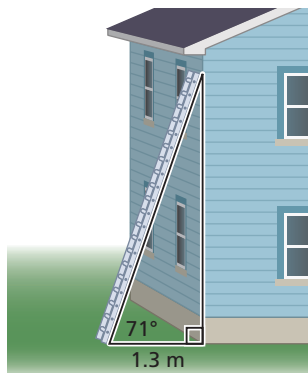

8. A helicopter is descending vertically. On the ground, a searchlight is 200 m from the point where the helicopter will land. It shines on the helicopter and the angle the beam makes with the ground is  $43^\circ$ . How high is the helicopter at this point to the nearest metre?

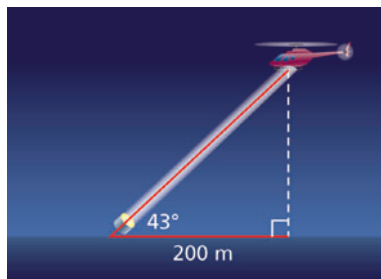

9. Determine the length of the hypotenuse of each right triangle to the nearest tenth of a centimetre. Describe your strategy.

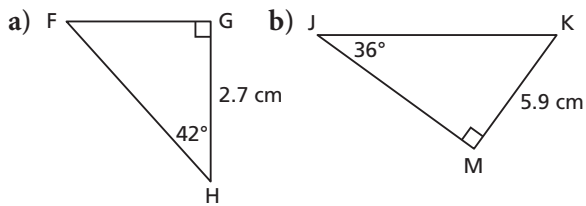

10. Claire knows that the Calgary Tower is 191 m high. At a certain point, the angle between the ground and Claire's line of sight to the top of the tower was  $81^\circ$ . To the nearest metre, about how far was Claire from the tower? Why is this distance approximate?



11. The angle between one longer side of a rectangle and a diagonal is  $34^\circ$ . One shorter side of the rectangle is 2.3 cm.  
 a) Sketch and label the rectangle.  
 b) What is the length of the rectangle to the nearest tenth of a centimetre?
12. In  $\triangle PQR$ ,  $\angle R = 90^\circ$ ,  $\angle P = 58^\circ$ , and  $PR = 7.1$  cm. Determine the area of  $\triangle PQR$  to the nearest tenth of a square centimetre. Describe your strategy.

13. The height of the Manitoba Legislature Building, from the ground to the top of the Golden Boy statue, is about 77 m. Liam is lying on the ground near the building. The angle between the ground and his line of sight to the top of the building is  $52^\circ$ . About how far is Liam from a point on the ground vertically below the statue? How do you know?



14. Janelle sees a large helium-filled balloon anchored to the roof of a store. When she is 100 m from the store, the angle between the ground and her line of sight to the balloon is  $30^\circ$ . About how high is the balloon? What assumptions are you making?

### C

15. In kite PQRS, the shorter diagonal, QS, is 6.0 cm long,  $\angle QRT = 26.5^\circ$ , and  $\angle QPT = 56.3^\circ$ . Determine the measures of all the angles and the lengths of the sides of the kite to the nearest tenth.

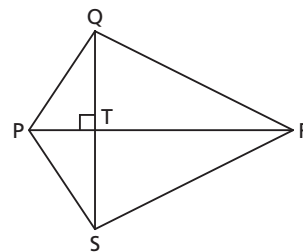

16. On a coordinate grid:  
 a) Draw a line through the points  $A(4, 5)$  and  $B(-4, -5)$ . Determine the measure of the acute angle between AB and the  $y$ -axis.  
 b) Draw a line through the points  $C(1, 4)$  and  $D(4, -2)$ . Determine the measure of the acute angle between CD and the  $x$ -axis.

### Reflect

Summarize what you have learned about using the tangent ratio to determine the length of a side of a right triangle.



# Measuring an Inaccessible Height

## LESSON FOCUS

Determine a height that cannot be measured directly.



## Make Connections

Tree farmers use a *clinometer* to measure the angle between a horizontal line and the line of sight to the top of a tree. They measure the distance to the base of the tree. How can they then use the tangent ratio to calculate the height of the tree?

## Construct Understanding

### TRY THIS

Work with a partner.

You will need:

- an enlarged copy of a  $180^\circ$  protractor
- scissors
- a measuring tape or 2 metre sticks
- a piece of heavy cardboard big enough for you to attach the paper protractor
- a drinking straw
- glue
- adhesive tape
- a needle and thread
- a small metal washer or weight
- grid paper

**A.** Make a drinking straw clinometer:

- Glue or tape the paper protractor to the cardboard. Carefully cut it out.
- Use the needle to pull the thread through the cardboard at the centre of baseline of the protractor. Secure the thread to the back of the cardboard with tape. Attach the weight to the other end of the thread.
- Tape the drinking straw along the baseline of the protractor for use as a sighting tube.

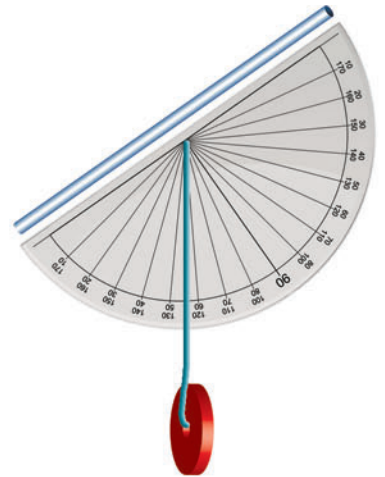
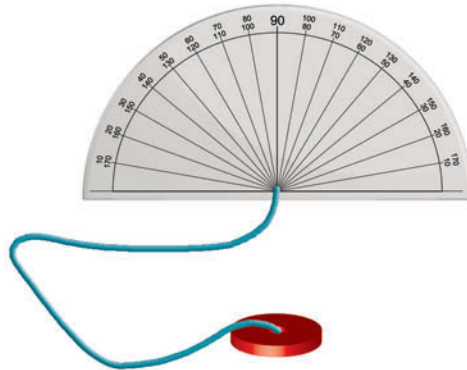
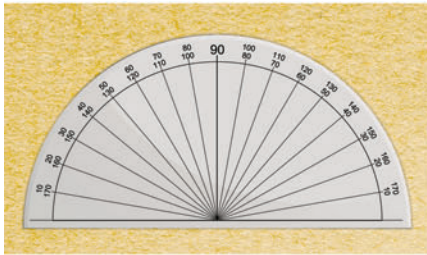

- B.** With your partner, choose a tall object whose height you cannot measure directly; for example, a flagpole, a totem pole, a tree, or a building.
- C.** One of you stands near the object on level ground. Your partner measures and records your distance from the object.
- D.** Hold the clinometer as shown, with the weight hanging down.

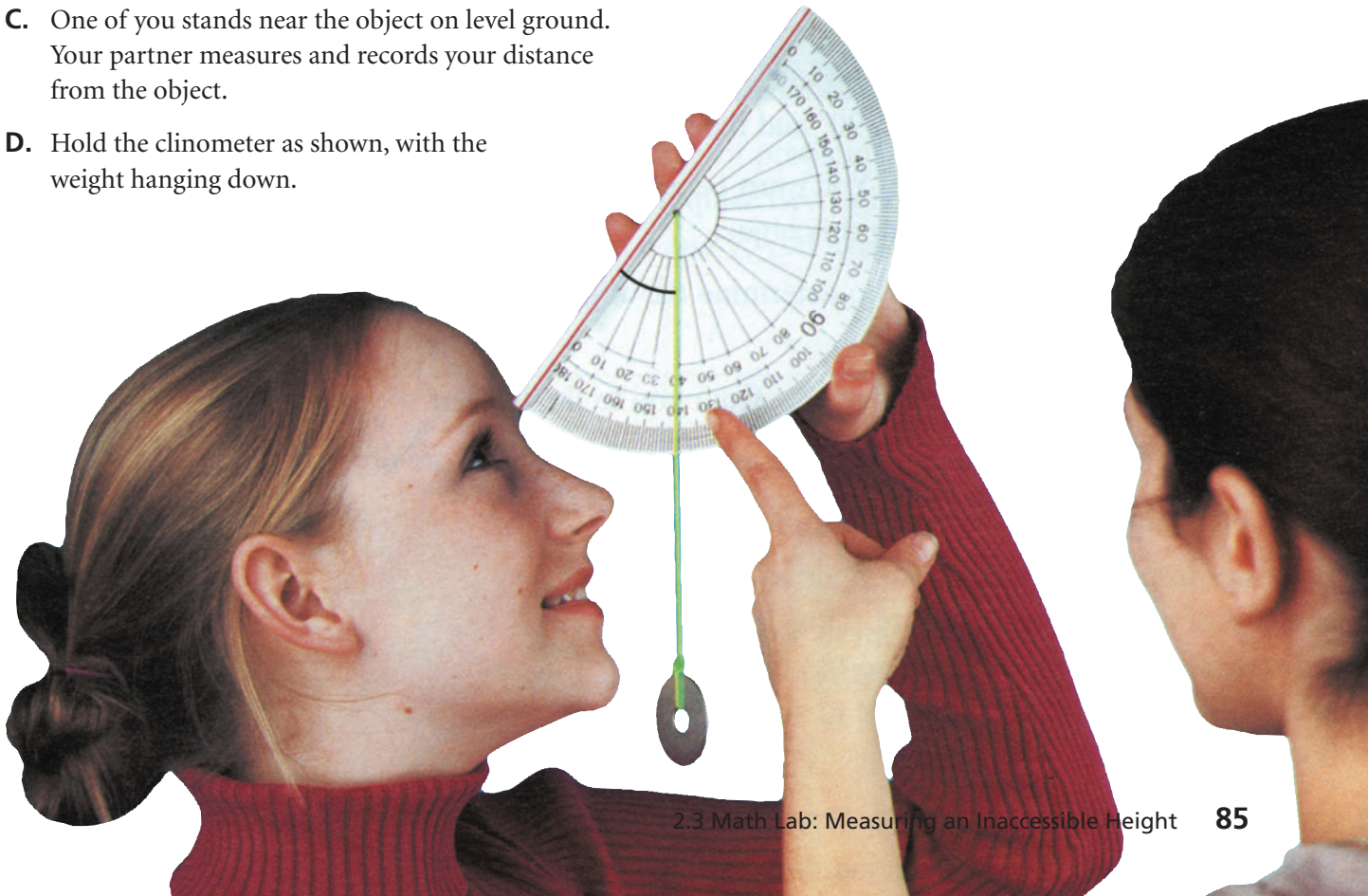

How does the acute angle between the thread and the straw relate to the angle of inclination of the straw?

What other strategy could you use to determine the height of the object?

- E. Look at the top of the object through the straw. Your partner records the acute angle indicated by the thread on the protractor.
- F. Your partner measures and records how far your eye is above the ground.
- G. Sketch a diagram with a vertical line segment representing the object you want to measure. Label:
  - your distance from the object
  - the vertical distance from the ground to your eyes
  - the angle of inclination of the straw
- H. Change places with your partner. Repeat Steps B to G.
- I. Use your measurements and the tangent ratio to calculate the height of the object.
- J. Compare your results with those of your partner. Does the height of your eye affect the measurements? The final result? Explain.

## Assess Your Understanding

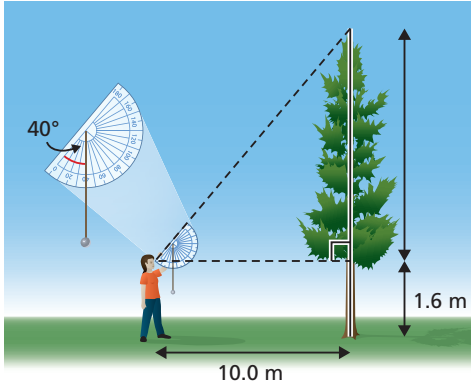
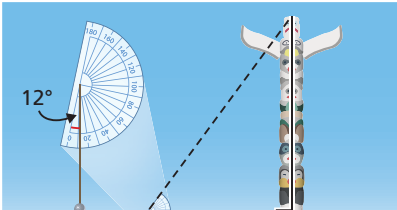
1. Explain how the angle shown on the protractor of your clinometer is related to the angle of inclination that the clinometer measures.
2. A tree farmer stood 10.0 m from the base of a tree. She used a clinometer to sight the top of the tree. The angle shown on the protractor scale was  $40^\circ$ . The tree farmer held the clinometer 1.6 m above the ground. Determine the height of the tree to the nearest tenth of a metre. The diagram is *not* drawn to scale.
3. Use the information in the diagram to calculate the height of a totem pole observed with a drinking-straw clinometer. Give the answer to the nearest metre. The diagram is *not* drawn to scale.

Keep your clinometer for use in the Review.

# CHECKPOINT 1

## Connections

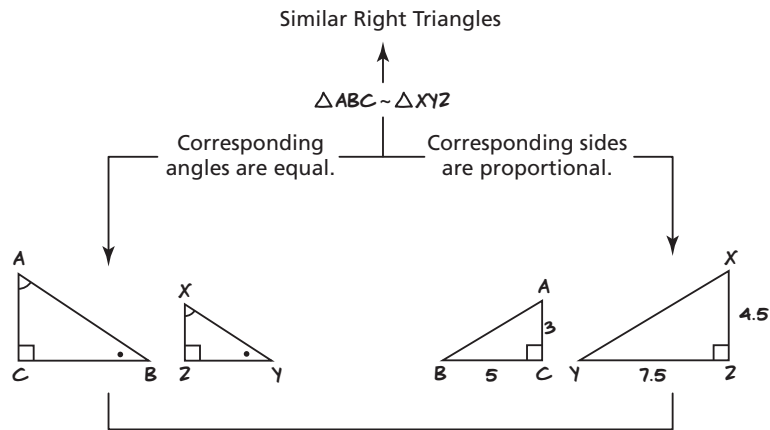

### Tangent Ratio

$$\tan B = \frac{\text{opposite}}{\text{adjacent}}$$

opposite to  $\angle B$   
adjacent to  $\angle B$

Determine an angle given two legs.

Determine a side given an angle and a leg.

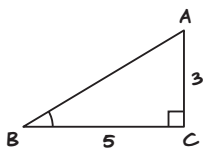

$$\tan B = \frac{\text{opposite}}{\text{adjacent}}$$

$$\tan B = \frac{3}{5}$$

$$\tan B = 0.6$$

$$\angle B \doteq 31^\circ$$

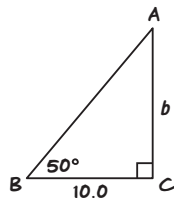

$$\tan B = \frac{\text{opposite}}{\text{adjacent}}$$

$$\tan 50^\circ = \frac{b}{10}$$

$$b = 10 \tan 50^\circ$$

$$b \doteq 11.9$$

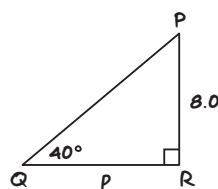

$$\tan Q = \frac{\text{opposite}}{\text{adjacent}}$$

$$\tan 40^\circ = \frac{8}{p}$$

$$p = \frac{8}{\tan 40^\circ}$$

$$p \doteq 9.5$$

or

$$\angle P = 90^\circ - \angle Q$$

$$\angle P = 50^\circ$$

$$\tan P = \frac{\text{opposite}}{\text{adjacent}}$$

$$\tan 50^\circ = \frac{p}{8}$$

$$p = 8 \tan 50^\circ$$

$$p \doteq 9.5$$

## In Lesson 2.1

- You applied what you know about similar right triangles to develop the concept of the **tangent ratio**.
- You used the tangent ratio to **determine an acute angle** in a right triangle when you know the lengths of the legs.

## In Lesson 2.2

- You showed how to determine the **length of a leg** in a right triangle when you know the measures of an acute angle and the other leg.

## In Lesson 2.3

- You applied the tangent ratio to a real-world measurement problem.

## Assess Your Understanding

### 2.1

1. Determine the measure of each indicated angle to the nearest degree.

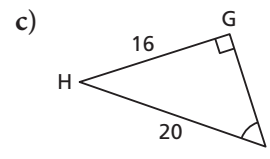
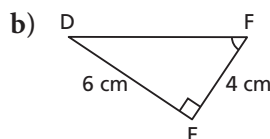
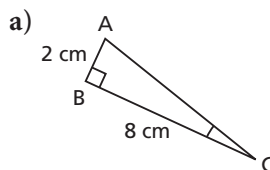

2. Why does the tangent of an angle increase as the angle increases?

3. A small plane is flying at an altitude of 1000 m and is 5000 m from the beginning of the landing strip. What is the angle between the ground and the line of sight from an observer at the beginning of the landing strip? Give the measure to the nearest tenth of a degree.



### 2.2

4. Determine the length of each indicated side to the nearest tenth of a centimetre.

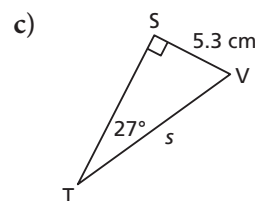
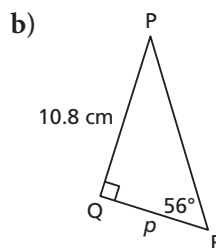
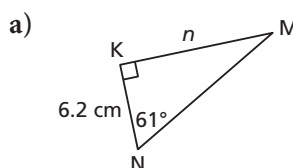

5. A hiker saw a hoodoo on a cliff at Willow Creek in Alberta's badlands. The hiker was 9.1 m from the base of the cliff. From that point, the angle between the level ground and the line of sight to the top of the hoodoo was  $69^\circ$ . About how high was the top of the hoodoo above the level ground?



## 2.4 The Sine and Cosine Ratios



### LESSON FOCUS

Develop and apply the sine and cosine ratios to determine angle measures.

### Make Connections

The railroad track through the mountains between Field, B.C., and Hector, B.C., includes spiral tunnels. They were built in the early 1900s to reduce the angle of inclination of the track between the two towns. You can see a long train passing under itself after it comes out of a tunnel before it has finished going in.

Visualize the track straightened out to form the hypotenuse of a right triangle. Here is a diagram of the track before the tunnels were constructed. The diagram is *not* drawn to scale.

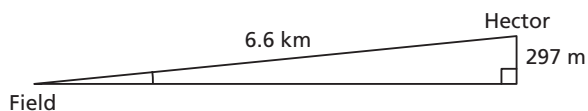

How could you determine the angle of inclination of the track?

# Construct Understanding

We defined the tangent ratio for an acute angle in a right triangle. There are two other ratios we can form to compare the sides of the triangle; each ratio involves the hypotenuse.

## TRY THIS

Work with a partner.

You will need grid paper, a ruler, and a protractor.

**A.** Examine the nested right triangles below.

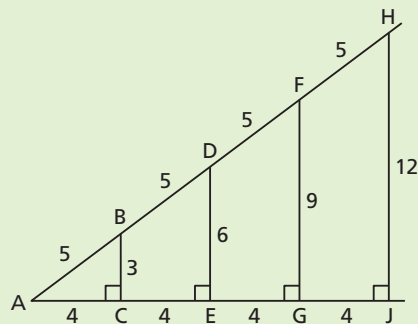

$\angle A$  is common to each triangle. How are the other acute angles in each triangle related? How do you know? How are the triangles related?

**B.** Copy and complete this table.

Triangle	Measures of Sides			Ratios	
	Hypotenuse	Side opposite $\angle A$	Side adjacent to $\angle A$	$\frac{\text{Side opposite } \angle A}{\text{Hypotenuse}}$	$\frac{\text{Side adjacent to } \angle A}{\text{Hypotenuse}}$
$\triangle ABC$					
$\triangle ADE$					
$\triangle AFG$					
$\triangle AHJ$					

- C.** Draw another set of nested right triangles that are not similar to those in Step A.
- D.** Measure the sides and angles of each triangle. Label your diagram with the measures, as in the diagram above.
- E.** Complete a table like the one in Step B for your triangles.
- F.** For each set of triangles, how do the ratios compare?
- G.** What do you think the value of each ratio depends on?

In a right triangle, the ratios that relate each leg to the hypotenuse depend only on the measure of the acute angle, and not on the size of the triangle. These ratios are called the **sine ratio** and the **cosine ratio**.

The sine ratio for  $\angle A$  is written as  $\sin A$  and the cosine ratio for  $\angle A$  is written as  $\cos A$ .

### The Sine Ratio

If  $\angle A$  is an acute angle in a right triangle, then

$$\sin A = \frac{\text{length of side opposite } \angle A}{\text{length of hypotenuse}}$$

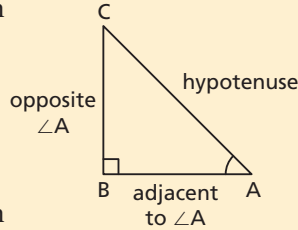

### The Cosine Ratio

If  $\angle A$  is an acute angle in a right triangle, then

$$\cos A = \frac{\text{length of side adjacent to } \angle A}{\text{length of hypotenuse}}$$

The tangent, sine, and cosine are called the **primary trigonometric ratios**. The word **trigonometry** comes from three Greek words “tri + gonia + metron” that together mean “three angle measure.”

The values of the sine and cosine that compare the lengths of the sides are often expressed as decimals. For example, in right  $\triangle ABC$ ,

If  $\sin A = 0.5$ , then in any similar right triangle, the length of the side opposite  $\angle A$  is 0.5 times the length of the hypotenuse.

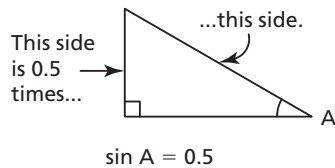

If  $\cos A = 0.7$ , then in any similar right triangle, the length of the side adjacent to  $\angle A$  is 0.7 times the length of the hypotenuse.

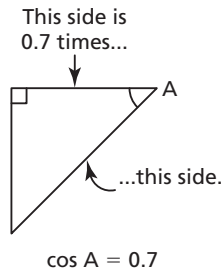

The branch of math that deals with the relations between the sides and angles of triangles is called **trigonometry**.

What happens to  $\sin A$  as  $\angle A$  gets closer to  $0^\circ$ ?

What happens to  $\cos A$  as  $\angle A$  gets closer to  $0^\circ$ ?



**Example 1****Determining the Sine and Cosine of an Angle**

- a) In  $\triangle DEF$ , identify the side opposite  $\angle D$  and the side adjacent to  $\angle D$ .
- b) Determine  $\sin D$  and  $\cos D$  to the nearest hundredth.

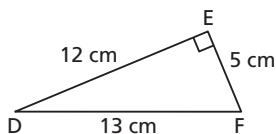
**SOLUTION**

- a) In right  $\triangle DEF$ ,  
 DF is the hypotenuse.  
 EF is opposite  $\angle D$  and  
 DE is adjacent to  $\angle D$ .

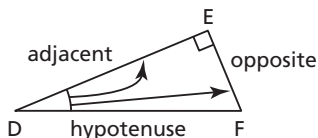

EF is opposite  $\angle D$ , DF is the hypotenuse.

b)  $\sin D = \frac{\text{opposite}}{\text{hypotenuse}}$

$$\sin D = \frac{EF}{DF}$$

$$\sin D = \frac{5}{13}$$

$$\sin D = 0.3846\dots$$

$$\sin D \doteq 0.38$$

$$\cos D = \frac{\text{adjacent}}{\text{hypotenuse}}$$

$$\cos D = \frac{DE}{DF}$$

$$\cos D = \frac{12}{13}$$

$$\cos D = 0.9230\dots$$

$$\cos D \doteq 0.92$$

DE is adjacent to  $\angle D$ , DF is the hypotenuse.

**CHECK YOUR UNDERSTANDING**

1. a) In  $\triangle GHJ$ , identify the side opposite  $\angle G$  and the side adjacent to  $\angle G$ .
- b) Determine  $\sin G$  and  $\cos G$  to the nearest hundredth.

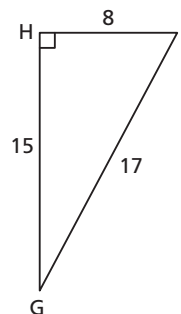

[Answers: a) HJ, HG  
 b)  $\sin G \doteq 0.47$ ;  $\cos G \doteq 0.88$  ]

Determine  $\sin F$  and  $\cos F$ . How are these values related to  $\sin D$  and  $\cos D$ ?

You can use a scientific calculator to determine the measure of an angle:

- When you know its sine, use  $\sin^{-1}$  or InvSin
- When you know its cosine, use  $\cos^{-1}$  or InvCos

## Example 2 Using Sine or Cosine to Determine the Measure of an Angle

Determine the measures of  $\angle G$  and  $\angle H$  to the nearest tenth of a degree.

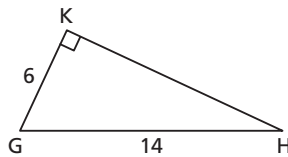

### SOLUTIONS

#### Method 1

Determine the measure of  $\angle H$  first.

In right  $\triangle GHK$ :

$$\sin H = \frac{\text{opposite}}{\text{hypotenuse}}$$

GK is opposite  $\angle H$ , GH is the hypotenuse.

$$\sin H = \frac{GK}{GH}$$

$$\sin H = \frac{6}{14}$$

$$\angle H = 25.3769\dots^\circ$$

$$\sin^{-1}(6/14) \\ 25.37693353$$

$$\angle G + \angle H = 90^\circ$$

$$\angle G = 90^\circ - \angle H$$

The angle sum of any triangle is  $180^\circ$ , so the two acute angles in a right triangle have a sum of  $90^\circ$ .

$$\text{So, } \angle G = 90^\circ - 25.3769\dots^\circ$$

$$\angle G = 64.6230\dots^\circ$$

#### Method 2

Determine the measure of  $\angle G$  first.

In right  $\triangle GHK$ :

$$\cos G = \frac{\text{adjacent}}{\text{hypotenuse}}$$

GK is adjacent to  $\angle G$ , GH is the hypotenuse.

$$\cos G = \frac{GK}{GH}$$

$$\cos G = \frac{6}{14}$$

$$\angle G = 64.6230\dots^\circ$$

$$\cos^{-1}(6/14) \\ 64.62306647$$

$$\angle G + \angle H = 90^\circ$$

The two acute angles have a sum of  $90^\circ$ .

$$\text{So, } \angle H = 90^\circ - 64.6230\dots^\circ$$

$$\angle H = 25.3769\dots^\circ$$

$\angle G$  is approximately  $64.6^\circ$  and

$\angle H$  is approximately  $25.4^\circ$ .

### CHECK YOUR UNDERSTANDING

- Determine the measures of  $\angle K$  and  $\angle M$  to the nearest tenth of a degree.

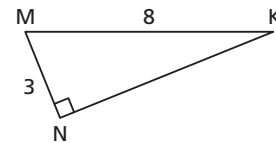

[Answer:  $\angle K \doteq 22.0^\circ$ ,  $\angle M \doteq 68.0^\circ$ ]

How are  $\cos G$  and  $\sin H$  related? Explain why this relationship occurs.

We can use the sine or cosine ratio to solve problems that can be modelled by a right triangle when we know the length of the hypotenuse, and the length of a leg or the measure of an acute angle.

### Example 3 Using Sine or Cosine to Solve a Problem

A water bomber is flying at an altitude of 5000 ft. The plane's radar shows that it is 8000 ft. from the target site. What is the **angle of elevation** of the plane measured from the target site, to the nearest degree?

#### SOLUTION

Draw a diagram to represent the situation.

Altitude is measured vertically.  
Assume the ground is horizontal.

$\angle R$  is the angle of elevation of the plane.

$AX$  is the altitude of the plane.

$RA$  is the distance from the target site to the plane.

In right  $\triangle ARX$ :

$$\sin R = \frac{AX}{RA}$$

$$\sin R = \frac{5000}{8000}$$

$$\angle R \doteq 39^\circ$$

$AX$  is opposite  $\angle R$ ,  $RA$  is the hypotenuse.

$$\sin^{-1}(5000/8000) \\ 38.68218745$$

The angle of elevation of the plane is approximately  $39^\circ$ .

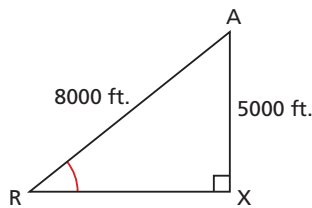

#### CHECK YOUR UNDERSTANDING

- An observer is sitting on a dock watching a float plane in Vancouver harbour. At a certain time, the plane is 300 m above the water and 430 m from the observer. Determine the angle of elevation of the plane measured from the observer, to the nearest degree.

[Answer: approximately  $44^\circ$ ]

The **angle of elevation** of an object above the horizontal is the angle between the horizontal and the line of sight from an observer.

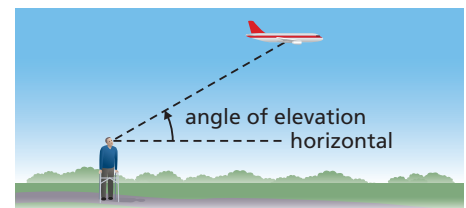

### Discuss the Ideas

- When can you use the sine ratio to determine the measure of an acute angle in a right triangle? When can you use the cosine ratio?
- Why is it important to draw a sketch before you start to solve a problem?
- Why are the values of the sine of an acute angle and the cosine of an acute angle less than 1?

# Exercises

## A

4. a) In each triangle below:

- Name the side opposite  $\angle A$ .
- Name the side adjacent to  $\angle A$ .
- Name the hypotenuse.

i)

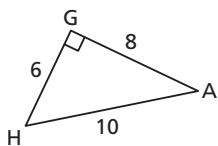

ii)

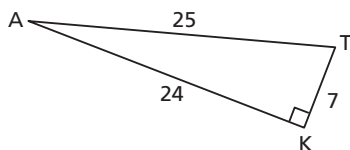

b) For each triangle in part a, determine  $\sin A$  and  $\cos A$  to the nearest hundredth.

5. Determine the sine and cosine of each angle to the nearest hundredth.

a)  $57^\circ$     b)  $5^\circ$     c)  $19^\circ$     d)  $81^\circ$

6. To the nearest degree, determine the measure of each  $\angle X$ .

a)  $\sin X = 0.25$     b)  $\cos X = 0.64$   
 c)  $\sin X = \frac{6}{11}$     d)  $\cos X = \frac{7}{9}$

## B

7. Determine the measure of each indicated angle to the nearest degree.

a)

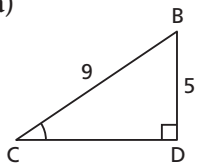

b)

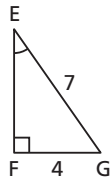

c)

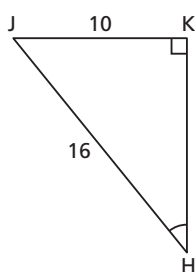

d)

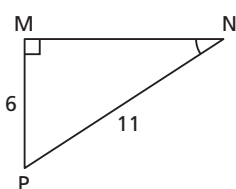

8. Determine the measure of each indicated angle to the nearest degree.

a)

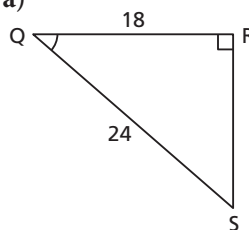

b)

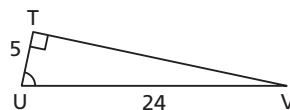

c)

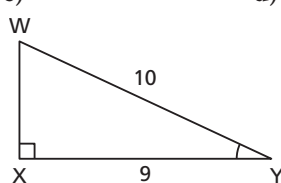

d)

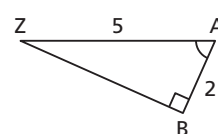

9. For each ratio below, sketch two different right triangles and label their sides.

a)  $\sin B = \frac{3}{5}$     b)  $\cos B = \frac{5}{8}$

c)  $\sin B = \frac{1}{4}$     d)  $\cos B = \frac{4}{9}$

10. Use the sine or cosine ratio to determine the measure of each acute angle to the nearest tenth of a degree. Describe your strategy.

a)



b)

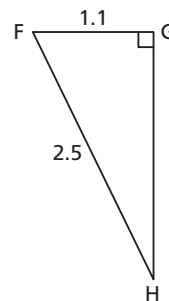

c)

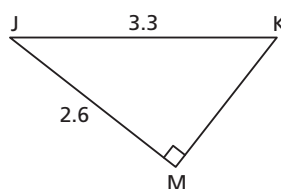

d)

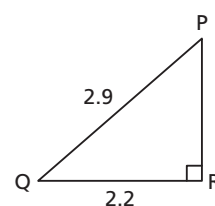

11. Suppose the railroad track through the spiral tunnels from Field to Hector were straightened out. It would look like the diagram below. The diagram is *not* drawn to scale. What is the angle of inclination of the track to the nearest tenth of a degree?

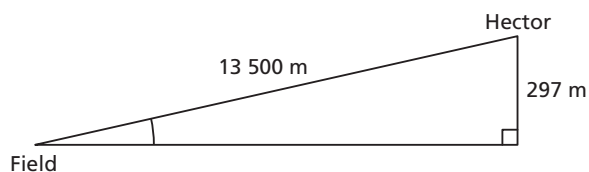

12. A ladder is 6.5 m long. It leans against a wall. The base of the ladder is 1.2 m from the wall. What is the angle of inclination of the ladder to the nearest tenth of a degree?
13. A rope that supports a tent is 2.4 m long. The rope is attached to the tent at a point that is 2.1 m above the ground. What is the angle of inclination of the rope to the nearest degree?



14. A rectangle is 4.8 cm long and each diagonal is 5.6 cm long. What is the measure of the angle between a diagonal and the longest side of the rectangle? Give the answer to the nearest degree.

15. a) Calculate:  
 i)  $\sin 10^\circ$     ii)  $\sin 20^\circ$     iii)  $\sin 40^\circ$   
 iv)  $\sin 50^\circ$     v)  $\sin 60^\circ$     vi)  $\sin 80^\circ$   
 b) Why does the sine of an angle increase as the angle increases?

16. Sketch a right isosceles triangle. Explain why the cosine of each acute angle is equal to the sine of the angle.

## C

17. A cylindrical silo is 37 ft. high and has a diameter of 14 ft. The top of the silo can be reached by a spiral staircase that circles the silo once. What is the angle of inclination of the staircase to the nearest degree?
18. a) We have defined the sine and cosine ratios for acute angles. Use a calculator to determine:  
 i)  $\sin 90^\circ$     ii)  $\sin 0^\circ$     iii)  $\cos 90^\circ$     iv)  $\cos 0^\circ$   
 b) Sketch a right triangle. Use the sketch to explain the results in part a.

## Reflect

Explain when you might use the sine or cosine ratio instead of the tangent ratio to determine the measure of an acute angle in a right triangle. Include examples in your explanation.



## THE WORLD OF MATH

### Careers: Tool and Die Maker

A tool and die maker constructs tools and prepares dies for manufacturing common objects, such as bottle caps. A *die* is made up of two plates that stamp together. A tool and die maker uses trigonometry to construct a die. She works from blueprints that show the dimensions of the design. To cut the material for a die, a tool and die maker must set the milling machine at the precise angle.

## 2.5 Using the Sine and Cosine Ratios to Calculate Lengths



### LESSON FOCUS

Use the sine and cosine ratios to determine lengths indirectly.

### Make Connections

A surveyor can measure an angle precisely using an instrument called a *transit*. A measuring tape is used to measure distances. How can the surveyor use these measures and her knowledge of trigonometry in a right triangle to calculate the lengths that cannot be measured directly?

### Construct Understanding

#### THINK ABOUT IT

Work with a partner.

The diagram shows measurements taken by surveyors. How could you determine the distance between the transit and the survey pole?

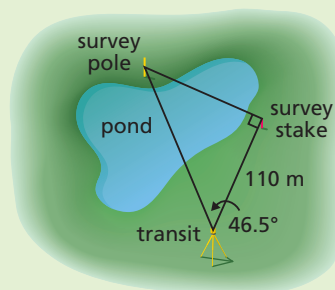

We can use the sine ratio or cosine ratio to write an equation that we can solve to calculate the length of a leg in a right triangle when the measure of one acute angle and the length of the hypotenuse are known.

### Example 1 Using the Sine or Cosine Ratio to Determine the Length of a Leg

Determine the length of BC to the nearest tenth of a centimetre.

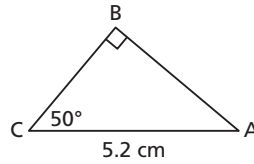

#### SOLUTION

In right  $\triangle ABC$ , AC is the hypotenuse and BC is adjacent to the known  $\angle C$ .

Choose the ratio that compares the adjacent side to the hypotenuse.

Use the cosine ratio to write an equation.

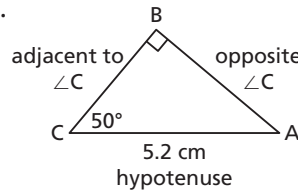

$$\cos C = \frac{\text{adjacent}}{\text{hypotenuse}}$$

$$\cos C = \frac{BC}{AC}$$

$$\cos 50^\circ = \frac{BC}{5.2}$$

Solve this equation for BC. Multiply both sides by 5.2.

$$5.2 \cos 50^\circ = \frac{(5.2)(BC)}{5.2}$$

$$5.2 \cos 50^\circ = BC$$

$$BC = 3.3424\dots$$

$5.2 \cos(50)$   
 $3.34249557$

BC is approximately 3.3 cm long.

#### CHECK YOUR UNDERSTANDING

- Determine the length of PQ to the nearest tenth of a centimetre.

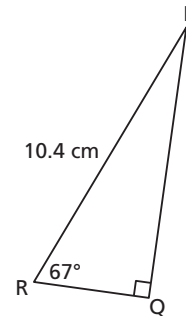

[Answer:  $PQ \approx 9.6$  cm]

How could you have used the sine ratio to solve this problem?

The sine and cosine ratios can be used to calculate the length of the hypotenuse when the measure of one acute angle and the length of one leg are known.

## Example 2

## Using Sine or Cosine to Determine the Length of the Hypotenuse

Determine the length of DE to the nearest tenth of a centimetre.

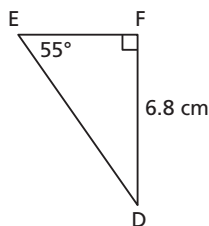

### SOLUTION

In right  $\triangle DEF$ , DE is the hypotenuse and DF is opposite the known  $\angle E$ .

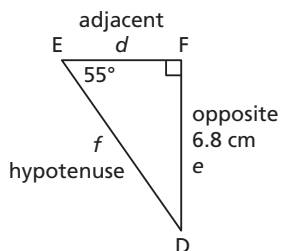

The sine ratio compares the opposite side to the hypotenuse. Use lower case letters to label the lengths of the sides.

Use the sine ratio to write an equation.

$$\sin E = \frac{\text{opposite}}{\text{hypotenuse}}$$

$$\sin E = \frac{e}{f}$$

$$\sin 55^\circ = \frac{6.8}{f}$$

Solve for  $f$ .

Multiply both sides by  $f$ .

$$f \sin 55^\circ = \frac{6.8 f}{f}$$

$$f \sin 55^\circ = 6.8$$

Divide both sides by  $\sin 55^\circ$ .

$$\frac{f \sin 55^\circ}{\sin 55^\circ} = \frac{6.8}{\sin 55^\circ}$$

$$f = \frac{6.8}{\sin 55^\circ}$$

$$f = 8.3012\dots$$

6.8/sin(55)

8.301267204

DE is approximately 8.3 cm long.

### CHECK YOUR UNDERSTANDING

2. Determine the length of JK to the nearest tenth of a centimetre.

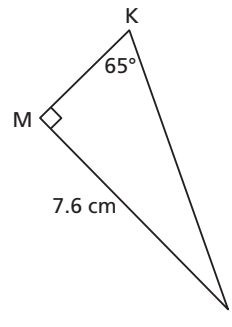

[Answer: JK  $\approx$  8.4 cm]



### Example 3 Solving an Indirect Measurement Problem

A surveyor made the measurements shown in the diagram. How could the surveyor determine the distance from the transit to the survey pole to the nearest hundredth of a metre?

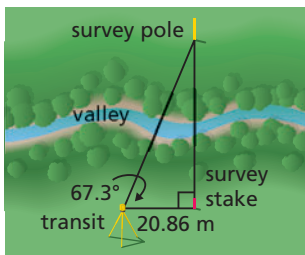

#### SOLUTION

Label a diagram to represent the problem.

The required distance is the hypotenuse of right  $\triangle PST$ .

In right  $\triangle PST$ ,  $TP$  is the hypotenuse and  $TS$  is adjacent to  $\angle T$ .

Use the cosine ratio to write an equation.

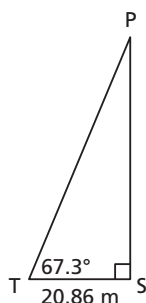

$$\cos T = \frac{\text{adjacent}}{\text{hypotenuse}}$$

$$\cos T = \frac{TS}{TP}$$

$$\cos 67.3^\circ = \frac{20.86}{TP}$$

Solve this equation for  $TP$ .

Multiply both sides by  $TP$ .

$$TP \cos 67.3^\circ = \frac{(TP)(20.86)}{TP}$$

$$TP \cos 67.3^\circ = 20.86$$

Divide both sides by  $\cos 67.3^\circ$ .

$$\frac{TP \cos 67.3^\circ}{\cos 67.3^\circ} = \frac{20.86}{\cos 67.3^\circ}$$

$$TP = \frac{20.86}{\cos 67.3^\circ}$$

$$TP = 54.0546\dots$$

$$\frac{20.86}{\cos(67.3)} = 54.05460841$$

The distance from the transit to the survey pole is approximately 54.05 m.

#### CHECK YOUR UNDERSTANDING

3. From a radar station, the angle of elevation of an approaching airplane is  $32.5^\circ$ . The horizontal distance between the plane and the radar station is 35.6 km. How far is the plane from the radar station to the nearest tenth of a kilometre?

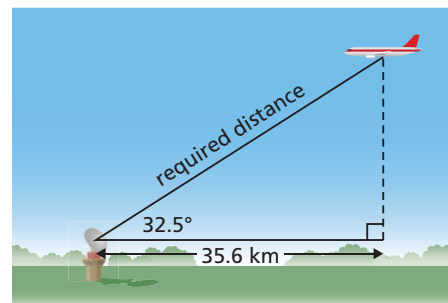

[Answer: 42.2 km]

How could you use the sine ratio instead of the cosine ratio to solve Example 3? How could you use the tangent ratio?

## Discuss the Ideas

1. What are the advantages of using a trigonometric ratio instead of an accurate drawing to solve a measurement problem?
2. When would you use the sine ratio to determine the length of a side of a right triangle? When would you use the cosine ratio?

## Exercises

### A

3. Determine the length of each indicated side to the nearest tenth of a centimetre.

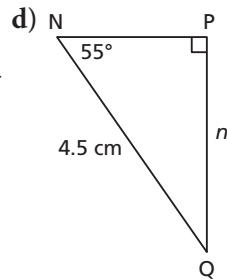
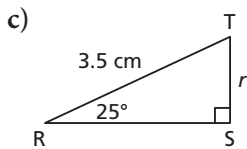
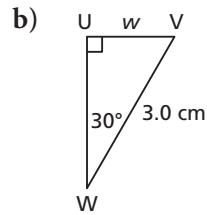
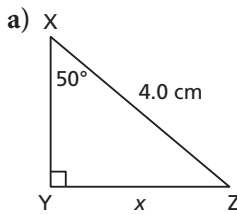

4. Determine the length of each indicated side to the nearest tenth of a centimetre.

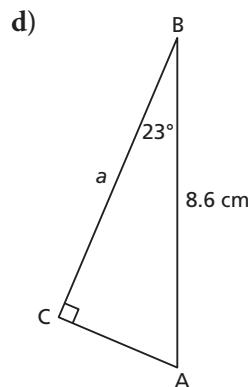
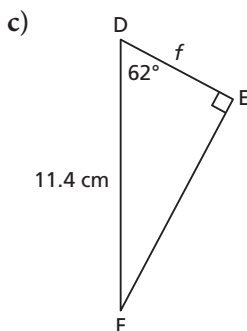
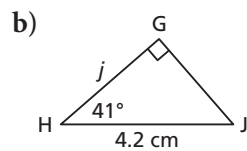
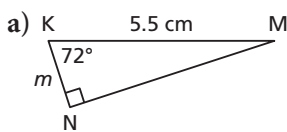

### B

5. Determine the length of each indicated side to the nearest tenth of a centimetre.

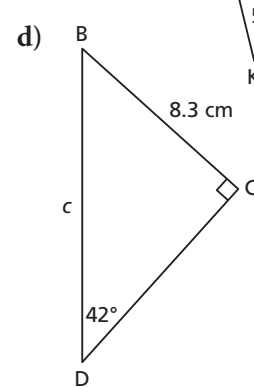
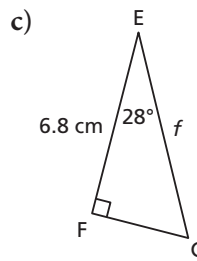
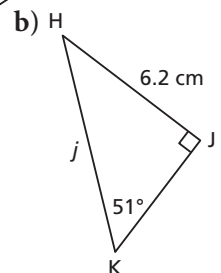
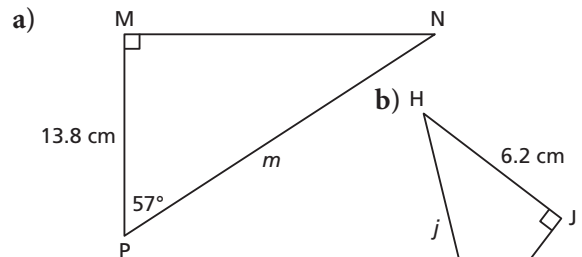

6. A fire truck has an aerial ladder that extends 30.5 m measured from the ground. The angle of inclination of the ladder is  $77^\circ$ . To the nearest tenth of a metre, how far up the wall of an apartment building can the ladder reach?

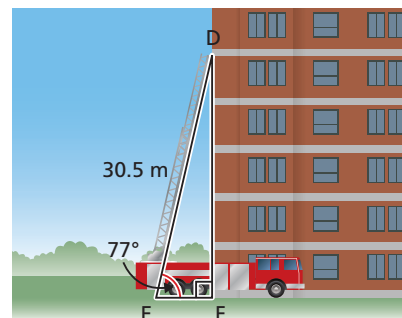

7. A surveyor makes the measurements shown in the diagram to determine the distance from C to E across a gorge.

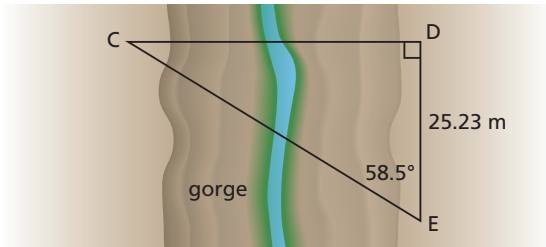

- a) To the nearest tenth of a metre, what is the distance from C to E?
- b) How could the surveyor calculate the distance from C to D?
8. A ship is sailing off the north coast of the Queen Charlotte Islands. At a certain point, the navigator sees the lighthouse at Langara Point, due south of the ship. The ship then sails 3.5 km due east. The angle between the ship's path and the line of sight to the lighthouse is then  $28.5^\circ$ . To the nearest tenth of a kilometre, how far is the ship from the lighthouse?



9. An airplane approaches an airport. At a certain time, it is 939 m high. Its angle of elevation measured from the airport is  $19.5^\circ$ . To the nearest metre, how far is the plane from the airport?
10. Calculate the dimensions of this rectangle to the nearest tenth of a centimetre.

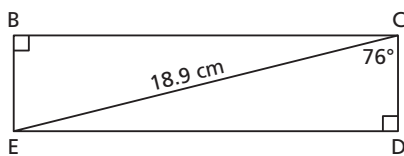

11. A bookcase is built against the sloping ceiling of an attic. The base of the bookcase is 3.24 m long. The angle of inclination of the attic ceiling is  $40^\circ$ .

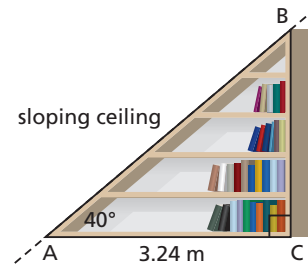

- a) What is the length of the top of the bookcase, measured along the attic ceiling?
- b) What is the greatest height of the bookcase? Give the answers to the nearest centimetre.
12. a) Determine the perimeter of each shape to the nearest tenth of a centimetre.
- i) ii)

- b) What strategies did you use to complete part a? What other strategies could you have used instead?

### C

13. In trapezoid CDEF,  $\angle D = \angle E = 90^\circ$ ,  $\angle C = 60^\circ$ ,  $EF = 4.5$  cm, and  $DE = 3.5$  cm. What is the perimeter of the trapezoid to the nearest millimetre? Describe your strategy.
14. A survey of a building lot that has the shape of an acute triangle shows these data:
- Two intersecting sides are 250 ft. and 170 ft. long.
  - The angle between these sides is  $55^\circ$ .
- a) Use the 250-ft. side as the base of the triangle. What is the height of the triangle?
- b) Determine the area of the lot to the nearest square foot.

### Reflect

Explain when you might use the sine or cosine ratio instead of the tangent ratio to determine the length of a side in a right triangle. Include examples.

# CHECKPOINT 2

## Connections

## Concept Development

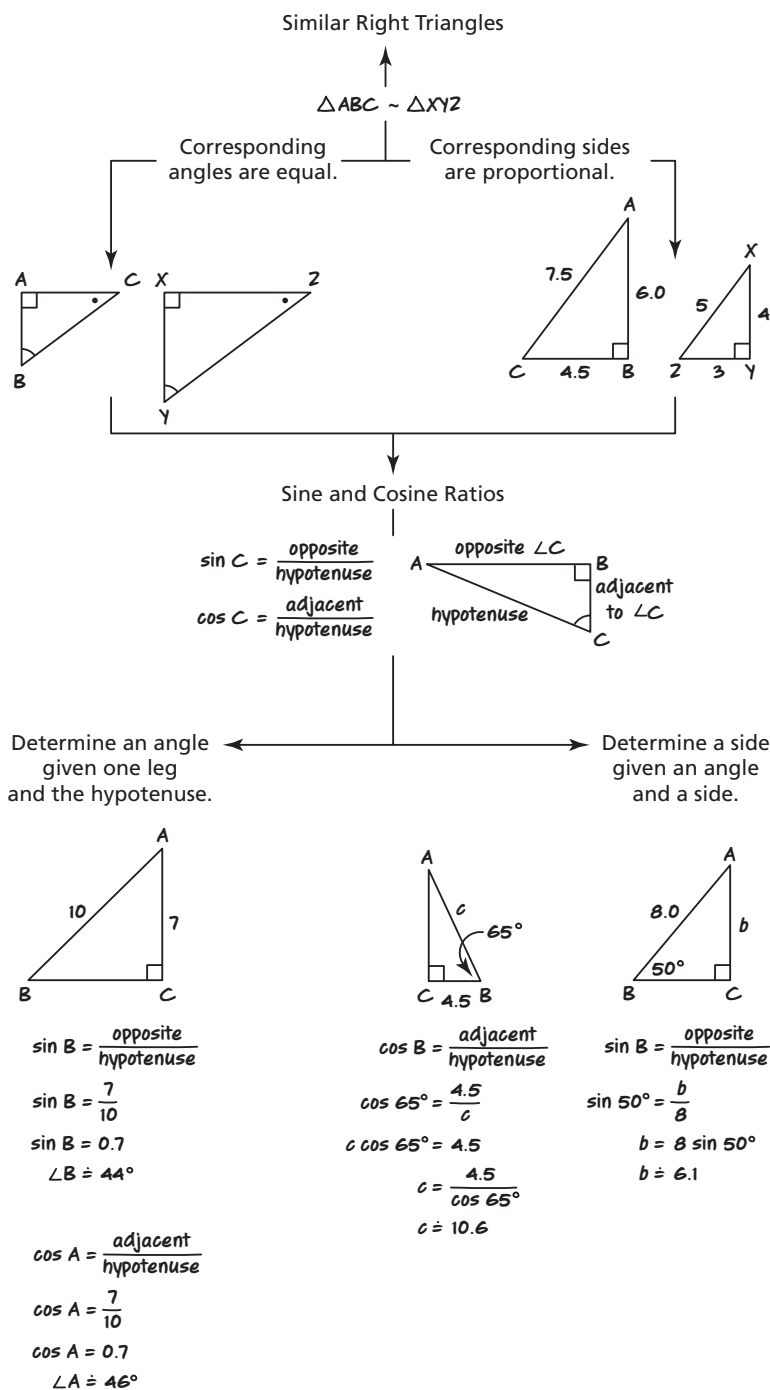

### In Lesson 2.4

- You applied what you know about similar right triangles to develop the **sine and cosine ratios**.
- You used the sine or cosine ratio **to determine an acute angle** in a right triangle when you know the lengths of one leg and the hypotenuse.

### In Lesson 2.5

- You showed how to determine the **length of a leg** in a right triangle when you know the measure of an acute angle and the length of the hypotenuse.
- You showed how to determine the **length of the hypotenuse** when you know the measure of an acute angle and the length of one leg.

## Assess Your Understanding

### 2.4

1. Determine the measure of each indicated angle to the nearest degree.

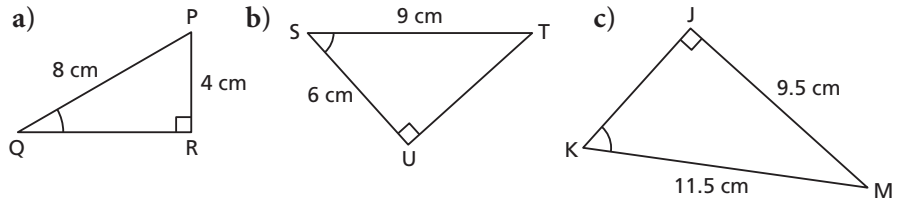

2. A factory manager plans to install a 30-ft. long conveyor that rises 7 ft. from the road to a loading dock. What is the angle of inclination of the conveyor to the nearest degree?

3. a) Calculate the cosine of each angle:  
 i)  $10^\circ$  ii)  $20^\circ$  iii)  $30^\circ$  iv)  $40^\circ$  v)  $50^\circ$  vi)  $60^\circ$  vii)  $70^\circ$  viii)  $80^\circ$   
 b) Explain why the cosine of an angle decreases as the angle increases.

### 2.5

4. Determine the length of each indicated side to the nearest tenth of a centimetre.

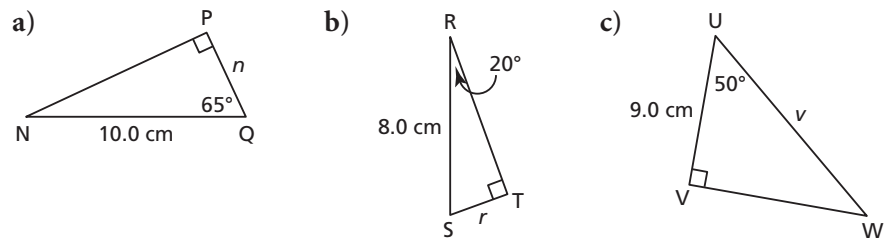

5. A ship is sailing off the south coast of the Queen Charlotte Islands. At a certain point, the navigator sees the beacon at Cape St. James, due north of the ship. The ship then sails 2.4 km due west. The angle between the ship's path and the line of sight to the beacon is  $41.5^\circ$ . How far is the ship from the beacon?



## 2.6 Applying the Trigonometric Ratios



### LESSON FOCUS

Use a primary trigonometric ratio to solve a problem modelled by a right triangle.

### Make Connections

Double-decker buses with wheelchair access ramps are used in Victoria, BC. When the bus is lowered, the extended ramp allows entry to the bus at about 4 in. above the sidewalk level. The ramp is about 3 ft. 3 in. long. How could you determine the angle of inclination of the ramp?

### Construct Understanding

#### THINK ABOUT IT

Work with a partner.

Anwar is designing a wheelchair accessibility ramp for his sister. He knows these data:

- The ramp will rise 1 ft. from the level ground to the door of the house.
- The horizontal distance from the start of the ramp at the sidewalk to the door is 20 ft.
- The building code states that the angle of inclination of the ramp must be less than  $5^\circ$ .

Determine whether Anwar's design will comply with the building code.

**Solving a triangle** means to determine the measures of all the angles and the lengths of all the sides in the triangle.

When we calculate the measures of all the angles and all the lengths in a right triangle, we **solve the triangle**. We can use any of the three primary trigonometric ratios to do this.

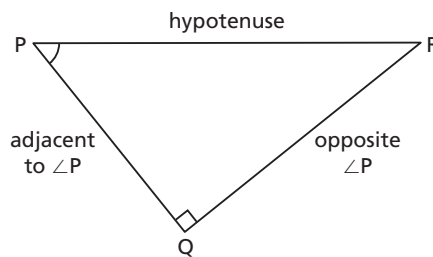

$$\tan P = \frac{\text{opposite}}{\text{adjacent}}$$

$$\sin P = \frac{\text{opposite}}{\text{hypotenuse}}$$

$$\cos P = \frac{\text{adjacent}}{\text{hypotenuse}}$$

### Example 1 Solving a Right Triangle Given Two Sides

Solve  $\triangle XYZ$ . Give the measures to the nearest tenth.

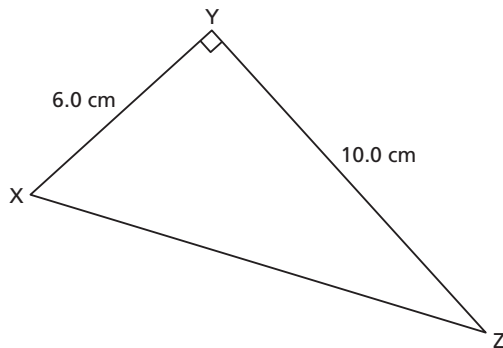

#### SOLUTIONS

##### Method 1

Determine the length of XZ first.

Use the Pythagorean Theorem in right  $\triangle XYZ$ .

$$XZ^2 = 6.0^2 + 10.0^2$$

$$XZ^2 = 36.00 + 100.00$$

$$XZ^2 = 136.00$$

$$XZ = \sqrt{136}$$

$$XZ = 11.6619\dots$$

XZ is approximately 11.7 cm.

#### CHECK YOUR UNDERSTANDING

1. Solve this triangle. Give the measures to the nearest tenth.

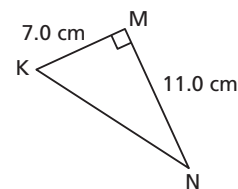

[Answers:  $KN \approx 13.0$  cm;  
 $\angle K \approx 57.5^\circ$ ;  $\angle N \approx 32.5^\circ$ ]

Determine the measure of  $\angle Z$ .

$$\cos Z = \frac{\text{adjacent}}{\text{hypotenuse}}$$

$$\cos Z = \frac{YZ}{XZ}$$

$$\cos Z = \frac{10.0}{\sqrt{136}}$$

$$\angle Z = 30.9637\dots^\circ$$

So,  $\angle X = 90^\circ - \angle Z$

$$\angle X = 59.0362\dots^\circ$$

Since YZ is adjacent to  $\angle Z$  and XZ is the hypotenuse, use the cosine ratio.

The acute angles in a right triangle have a sum of  $90^\circ$ .

### Method 2

Determine the angle measures first.

Determine the measure of  $\angle Z$  in right  $\triangle XYZ$ .

$$\tan Z = \frac{\text{opposite}}{\text{adjacent}}$$

$$\tan Z = \frac{XY}{YZ}$$

$$\tan Z = \frac{6.0}{10.0}$$

$$\tan Z = 0.6$$

$$\angle Z = 30.9637\dots^\circ$$

So,  $\angle X = 90^\circ - \angle Z$

$$\angle X = 59.0362\dots^\circ$$

Since YZ is adjacent to  $\angle Z$  and XY is opposite  $\angle Z$ , use the tangent ratio.

The acute angles in a right triangle have a sum of  $90^\circ$ .

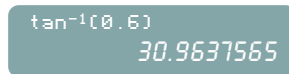

```
tan-1(0.6)
30.9637565
```

Determine the length of XZ.

$$\cos Z = \frac{\text{adjacent}}{\text{hypotenuse}}$$

$$\cos Z = \frac{YZ}{XZ}$$

$$\cos 30.9637\dots^\circ = \frac{10.0}{XZ}$$

Solve the equation for XZ.  
Multiply both sides by XZ.

$$XZ \cos 30.9637\dots^\circ = 10.0$$

Divide both sides by  $\cos 30.9637\dots^\circ$

$$XZ = \frac{10.0}{\cos 30.9637\dots^\circ}$$

$$XZ = 11.6614\dots$$

XZ is approximately 11.7 cm.

$\angle X$  is approximately  $59.0^\circ$  and

$\angle Z$  is approximately  $31.0^\circ$ .

Which other trigonometric ratio could you have used in Method 1? Why might it be better to use this ratio?



## Example 2 Solving a Right Triangle Given One Side and One Acute Angle

Solve this triangle. Give the measures to the nearest tenth where necessary.

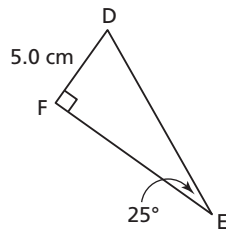

### SOLUTION

Label a diagram.

Determine the measure of  $\angle D$  first.

In right  $\triangle DEF$ :

$$\angle D + \angle E = 90^\circ$$

$$\angle D = 90^\circ - 25^\circ$$

$$\angle D = 65^\circ$$

Determine the length of EF.

$$\tan D = \frac{\text{opposite}}{\text{adjacent}}$$

$$\tan D = \frac{d}{5.0}$$

$$\tan 65^\circ = \frac{d}{5.0}$$

$$5.0 \tan 65^\circ = d$$

$$d = 10.7225\dots$$

EF is approximately 10.7 cm.

Use the sine ratio to calculate the length of DE.

$$\sin E = \frac{\text{opposite}}{\text{hypotenuse}}$$

$$\sin E = \frac{5.0}{f}$$

$$\sin 25^\circ = \frac{5.0}{f}$$

$$f \sin 25^\circ = 5.0$$

$$f = \frac{5.0}{\sin 25^\circ}$$

$$f = 11.8310\dots$$

DE is approximately 11.8 cm.

Since EF is opposite  $\angle D$  and DF is adjacent to  $\angle D$ , use the tangent ratio.

Solve the equation for  $d$ .  
Multiply both sides by 5.0.

Solve the equation for  $f$ .  
Multiply both sides by  $f$ .

Divide both sides by  $\sin 25^\circ$ .

### CHECK YOUR UNDERSTANDING

2. Solve this triangle. Give the measures to the nearest tenth where necessary.

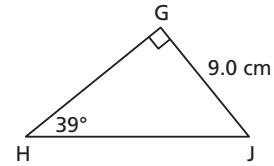

[Answers:  $\angle J = 51^\circ$ ;  $GH \doteq 11.1$  cm;  
 $HJ \doteq 14.3$  cm]

What is the advantage of determining the unknown angle before the unknown sides?

### Example 3 Solving a Problem Using the Trigonometric Ratios

A small table has the shape of a regular octagon. The distance from one vertex to the opposite vertex, measured through the centre of the table, is approximately 30 cm. There is a strip of wood veneer around the edge of the table. What is the length of this veneer to the nearest centimetre?

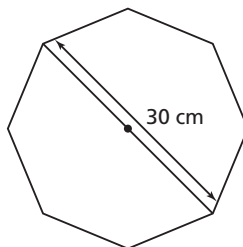

#### SOLUTION

To determine the length of veneer, calculate the perimeter of the surface of the table.

Since the surface of the table is a regular octagon, congruent isosceles triangles are formed by drawing line segments from the centre of the surface to each vertex.

In each triangle, the angle at the centre is:

$$360^\circ \div 8 = 45^\circ$$

The line segment from the centre of the octagon to the centre of each side of the octagon bisects each central angle and is perpendicular to the side.

So, in right  $\triangle ABC$ ,

$$\angle A = 22.5^\circ \text{ and } AB = 15 \text{ cm}$$

$$\sin A = \frac{BC}{AB} \quad \begin{array}{l} \text{Solve the equation for BC.} \\ \text{Multiply both sides by 15.} \end{array}$$

$$\sin 22.5^\circ = \frac{BC}{15}$$

$$15 \sin 22.5^\circ = BC$$

Since  $BC = 15 \sin 22.5^\circ$ , then  $BD = 2(15 \sin 22.5^\circ)$ , and  $BD = 30 \sin 22.5^\circ$

And, the perimeter of the octagon is:

$$8(BD) = 8(30 \sin 22.5^\circ)$$

$$8(BD) = 91.8440\dots$$

The length of veneer required is approximately 92 cm.

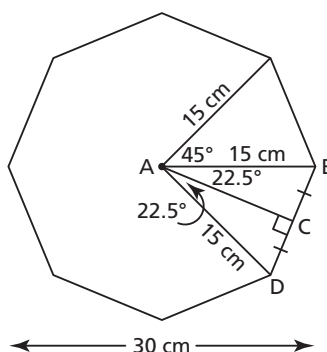

#### CHECK YOUR UNDERSTANDING

3. A window has the shape of a regular decagon. The distance from one vertex to the opposite vertex, measured through the centre of the window, is approximately 4 ft. Determine the length of the wood moulding material that forms the frame of the window, to the nearest foot.

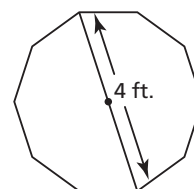

[Answer: approximately 12 ft.]

$$8(30 \sin 22.5^\circ) \\ 91.84402377$$



## THE WORLD OF MATH

### Profile: Renewable Energy

Aboriginal and northern communities are committed to developing sustainable energy from sources such as wind turbines, solar panels, geothermal, and hydroelectric projects.

Weather Dancer 1 is a 900 KW wind turbine situated on Piikani Nation land in southern Alberta. First commissioned in 2001, it was developed and is run as a joint venture by the Piikani Indian Utility Corporation and EPCOR, a City of Edmonton power company. Weather Dancer 1 generates 9960 MWh of carbon-dioxide free power each year. It was named in honour of Okan (Sun Dance), a traditional ceremony of the Blackfoot that renews their relationship with the life forces of nature.

How could you use trigonometry to determine the length of a blade of a wind turbine?

### Discuss the Ideas

1. When we solve a right triangle, sometimes we determine the measure of an unknown angle before we determine the length of an unknown side and sometimes we reverse these calculations. How would you decide which measure to calculate first?
2. Can we solve a right triangle if we are given only the measures of the two acute angles? Explain.

# Exercises

## A

3. To determine the measure of each indicated angle, which trigonometric ratio would you use? Why?

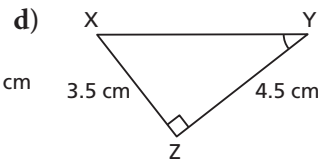
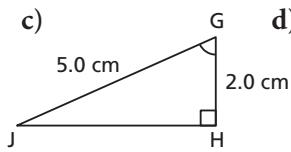
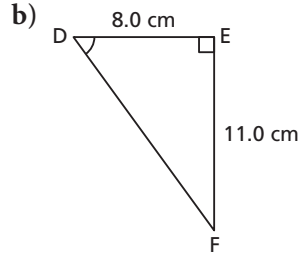
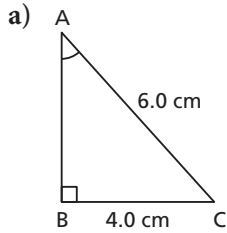

4. Determine the length of each indicated side to the nearest tenth of a centimetre. Which trigonometric ratio did you use? Why?

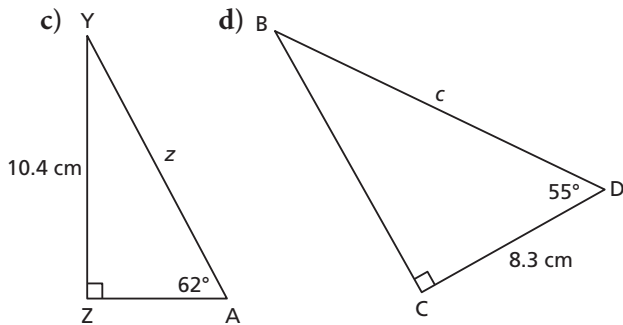
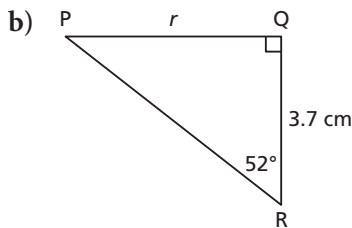
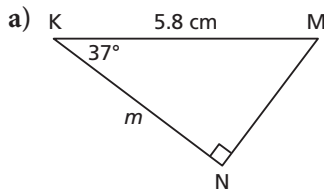

5. To determine the length of each indicated side, which strategy would you use? Why?

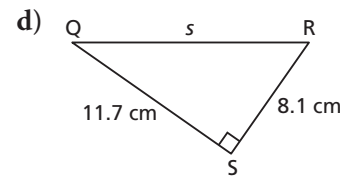
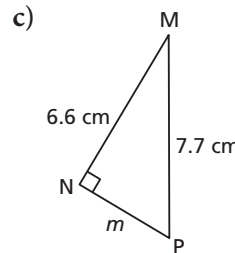
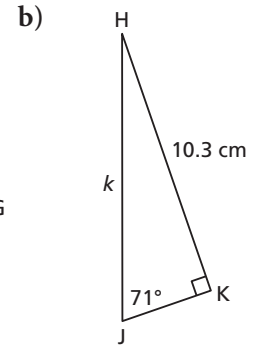
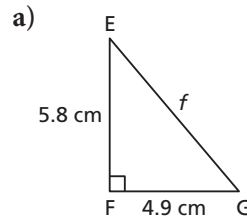

## B

6. Solve each right triangle. Give the measures to the nearest tenth.

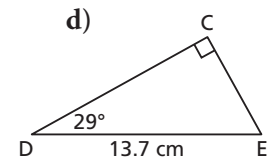
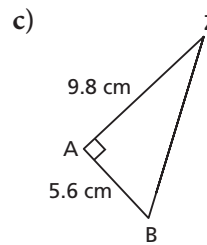
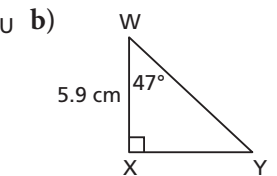
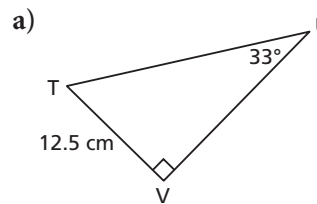

7. An architect draws this diagram of a wheelchair entrance ramp for a building.

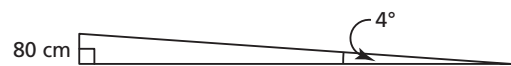

- a) Determine the length of the ramp.  
 b) Determine the horizontal distance the ramp will take up.  
 Give the measures to the nearest centimetre.

8. The world's tallest totem pole is in Alert Bay, B.C., home of the Nimpkish First Nation. Twenty feet from the base of the totem pole, the angle of elevation of the top of the pole is  $83.4^\circ$ . How tall is the totem pole to the nearest foot?



9. A helicopter leaves its base, and flies 35 km due west to pick up a sick person. It then flies 58 km due north to a hospital.
- When the helicopter is at the hospital, how far is it from its base to the nearest kilometre?
  - When the helicopter is at the hospital, what is the measure of the angle between the path it took due north and the path it will take to return directly to its base? Write the angle to the nearest degree.

10. A road rises 1 m for every 15 m measured along the road.
- What is the angle of inclination of the road to the nearest degree?
  - How far does a car travel horizontally when it travels 15 m along the road? Give the answer to the nearest tenth of a metre.

11. A roof has the shape of an isosceles triangle with equal sides 7 m long and base 12 m long.
- What is the measure of the angle of inclination of the roof to the nearest degree?
  - What is the measure of the angle at the peak of the roof to the nearest degree?



12. Determine the perimeter and area of each shape. Give the measures to the nearest tenth.

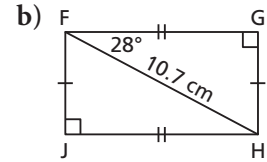
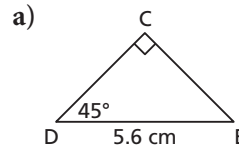

13. Determine the perimeter of this rhombus to the nearest tenth of a centimetre.

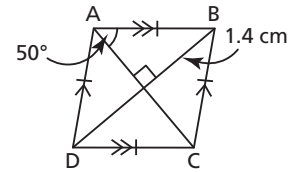

14. A candle has the shape of a right prism whose bases are regular polygons with 12 sides. On each base, the distance from one vertex to the opposite vertex, measured through the centre of the base, is approximately 2 in. The candle is 5 in. high.
- What is the area of the base, to the nearest square inch?
  - What is the volume of wax in the candle, to the nearest cubic inch?

### C

15. To irrigate crops, a farmer uses a boom sprayer pulled by a tractor. The nozzles are 50 cm apart and spray at an angle of  $70^\circ$ . To the nearest centimetre, how high should the sprayer be placed above the crops to ensure that all the crops are watered?

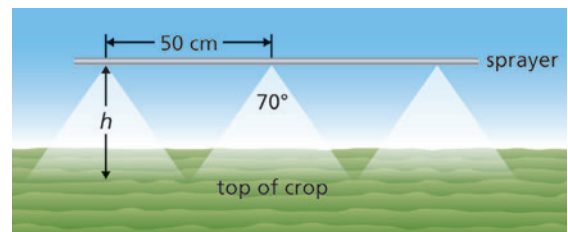

16. Determine the perimeter and area of this isosceles trapezoid. Give the measures to the nearest tenth.

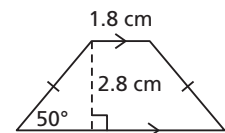

### Reflect

How does the information you are given about a right triangle determine the steps you take to solve the triangle? Include examples with your explanation.

## 2.7 Solving Problems Involving More than One Right Triangle



### LESSON FOCUS

Use trigonometry to solve problems modelled by more than one right triangle.

### Make Connections

The Muttart Conservatory in Edmonton has four climate-controlled square pyramids, each representing a different climatic zone. Each of the tropical and temperate pyramids is 24 m high and the side length of its base is 26 m. How do you think the architects determined the angles at which to cut the glass pieces for each face at the apex of the pyramid?

### Construct Understanding

#### THINK ABOUT IT

Work with a partner.

Sketch a square pyramid.

Label its height and base with the measurements above.

Draw right triangles on your sketch that would help you determine the angle between the edges of the pyramid at its apex.

How could you use trigonometry to help you determine this angle?

We can use trigonometry to solve problems that can be modelled using right triangles. When more than one right triangle is involved, we have to decide which triangle to start with.

**Example 1****Calculating a Side Length Using More than One Triangle**

Calculate the length of CD to the nearest tenth of a centimetre.

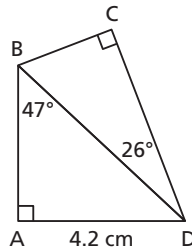
**SOLUTION**

The length of CD cannot be determined in one step because we know only the measure of one angle in  $\triangle BCD$ . So, use  $\triangle ABD$  to calculate the length of BD.

In right  $\triangle ABD$ , AD is opposite  $\angle ABD$  and BD is the hypotenuse.

Use the sine ratio in  $\triangle ABD$ .

$$\sin B = \frac{\text{opposite}}{\text{hypotenuse}}$$

$$\sin B = \frac{AD}{BD}$$

$$\sin 47^\circ = \frac{4.2}{BD}$$

$$BD \sin 47^\circ = 4.2$$

$$BD = \frac{4.2}{\sin 47^\circ}$$

$$BD = 5.7427\dots$$

In right  $\triangle BCD$ , CD is adjacent to  $\angle BDC$  and BD is the hypotenuse.

Use the cosine ratio in  $\triangle BCD$ .

$$\cos D = \frac{\text{adjacent}}{\text{hypotenuse}}$$

$$\cos D = \frac{CD}{BD}$$

$$\cos 26^\circ = \frac{CD}{5.7427\dots}$$

$$(5.7427\dots)\cos 26^\circ = CD$$

$$CD = 5.1615\dots$$

CD is approximately 5.2 cm.

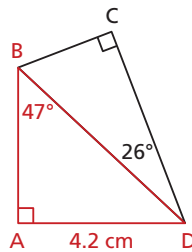

Solve for BD. Multiply both sides by BD.

Divide both sides by  $\sin 47^\circ$ .

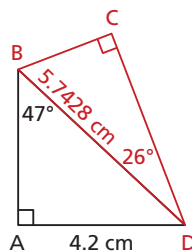

Solve for CD. Multiply both sides by 5.7427...

**CHECK YOUR UNDERSTANDING**

1. Calculate the length of XY to the nearest tenth of a centimetre.

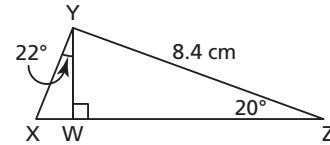

[Answer:  $XY \approx 3.1$  cm]

Explain how you could calculate all the unknown sides and angles of quadrilateral ABCD.

## Example 2 Solving a Problem with Triangles in the Same Plane

From the top of a 20-m high building, a surveyor measured the angle of elevation of the top of another building and the **angle of depression** of the base of that building.

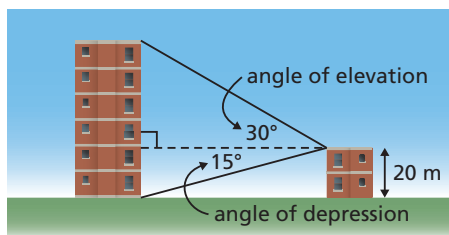

The surveyor sketched this plan of her measurements. Determine the height of the taller building to the nearest tenth of a metre.

### SOLUTION

Draw and label a diagram. The height of the building is represented by PR.

$$PR = PS + SR$$

In  $\triangle PQS$ , we know only the measure of  $\angle PQS$ . So, use right  $\triangle QRS$  to calculate the length of SQ. QSRT is a rectangle, so  $SR = QT = 20$  m.

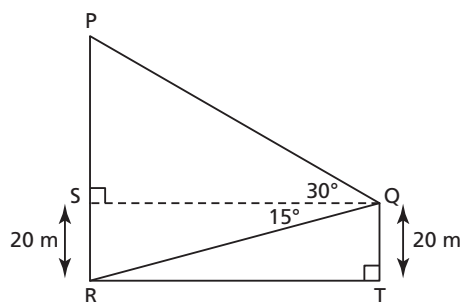

We cannot calculate PR in one step because it is not a side of a right triangle.

Use the tangent ratio in  $\triangle QRS$ .

$$\tan Q = \frac{\text{opposite}}{\text{adjacent}}$$

$$\tan Q = \frac{SR}{QS}$$

$$\tan 15^\circ = \frac{20}{QS}$$

$$QS \tan 15^\circ = 20$$

$$QS = \frac{20}{\tan 15^\circ}$$

$$QS = 74.6410\dots$$

Solve the equation for QS. Multiply both sides by QS.

Divide both sides by  $\tan 15^\circ$ .

(Solution continues.)

### CHECK YOUR UNDERSTANDING

- A surveyor stands at a window on the 9th floor of an office tower. He uses a clinometer to measure the angles of elevation and depression of the top and the base of a taller building. The surveyor sketches this plan of his measurements. Determine the height of the taller building to the nearest tenth of a metre.

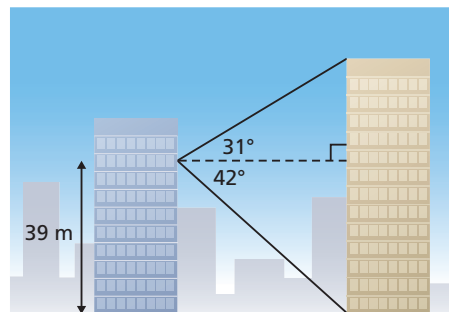

[Answer: Approximately 65.0 m]

The **angle of depression** of an object below the horizontal is the angle between the horizontal and the line of sight from an observer.

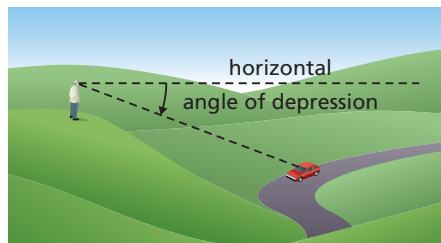



Use the tangent ratio in  $\triangle PQS$ .

$$\tan Q = \frac{\text{opposite}}{\text{adjacent}}$$

$$\tan Q = \frac{PS}{QS}$$

$$\tan 30^\circ = \frac{PS}{74.6410\dots}$$

Solve the equation for PS.  
Multiply both sides by 74.6410...

$$(74.6410\dots) \tan 30^\circ = PS$$

$$PS = 43.0940\dots$$

So,  $PR = PS + SR$

$$PR = 43.0940\dots + 20$$

$$= 63.0940\dots$$

The taller building is approximately 63.1 m high.

Suppose you did not evaluate a decimal equivalent for QS. What expression would you need to use to determine the length of PS?

Sometimes the right triangles we solve are not in the same plane.

### Example 3 Solving a Problem with Triangles in Different Planes

From the top of a 90-ft. observation tower, a fire ranger observes one fire due west of the tower at an angle of depression of  $5^\circ$ , and another fire due south of the tower at an angle of depression of  $2^\circ$ .

How far apart are the fires to the nearest foot?

The diagram is *not* drawn to scale.

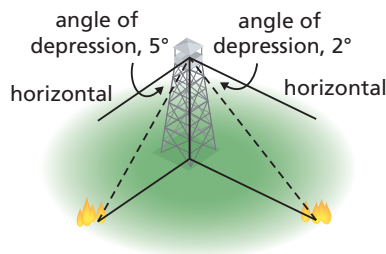

#### SOLUTION

Label a diagram.

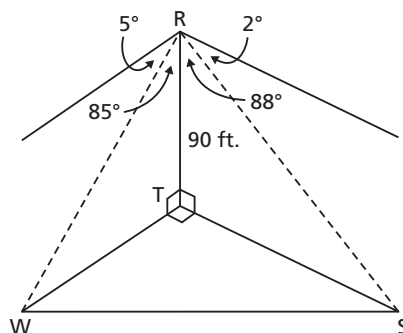

The fires are due south and due west of the tower, so the angle between the lines of sight, TW and TS, to the fires from the base of the tower is  $90^\circ$ .

Since the angles of depression are  $5^\circ$  and  $2^\circ$  respectively, the angles between the tower, RT, and the lines of sight are  $85^\circ$  and  $88^\circ$  respectively.

To calculate the distance WS between the fires, first calculate the distances, TW and TS, of the fires from the base of the tower.

Use the tangent ratio in right  $\triangle RTW$ .

$$\tan R = \frac{\text{opposite}}{\text{adjacent}}$$

$$\tan R = \frac{WT}{RT}$$

$$\tan 85^\circ = \frac{WT}{90} \quad \text{Solve for WT. Multiply both sides by 90.}$$

$$90 \tan 85^\circ = WT$$

$$WT = 1028.7047\dots$$

Use the tangent ratio in right  $\triangle RTS$ .

$$\tan R = \frac{\text{opposite}}{\text{adjacent}}$$

$$\tan R = \frac{TS}{RT}$$

$$\tan 88^\circ = \frac{TS}{90} \quad \text{Solve for TS. Multiply both sides by 90.}$$

$$90 \tan 88^\circ = TS$$

$$TS = 2577.2627\dots$$

In right  $\triangle STW$ , use the Pythagorean Theorem.

$$SW^2 = WT^2 + TS^2$$

$$SW^2 = 1028.7047\dots^2 + 2577.2627\dots^2$$

$$SW = \sqrt{1028.7047\dots^2 + 2577.2627\dots^2}$$

$$= 2774.9805\dots$$

The distance between the fires is approximately 2775 ft.

### CHECK YOUR UNDERSTANDING

3. A communications tower is 35 m tall. From a point due north of the tower, Tannis measures the angle of elevation of the top of the tower as  $70^\circ$ . Her brother Leif, who is due east of the tower, measures the angle of elevation of the top of the tower as  $50^\circ$ . How far apart are the students to the nearest metre? The diagram is *not* drawn to scale.

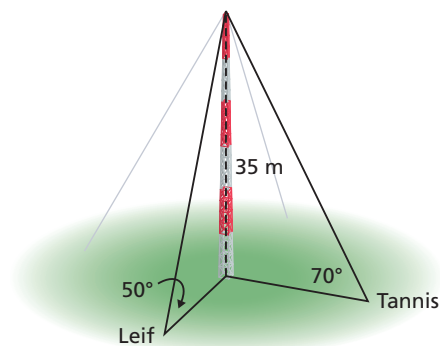

[Answer: About 32 m]

Solve Example 3 using your calculator only once. Explain why this might be more efficient and accurate than calculating intermediate lengths.

## Discuss the Ideas

1. What do you have to think about when you draw a diagram with triangles in three dimensions?
2. When you have to solve a problem that involves two right triangles, how do you decide where to begin?

## Exercises

### A

3. In each triangle, determine the length of JK to the nearest tenth of a centimetre.

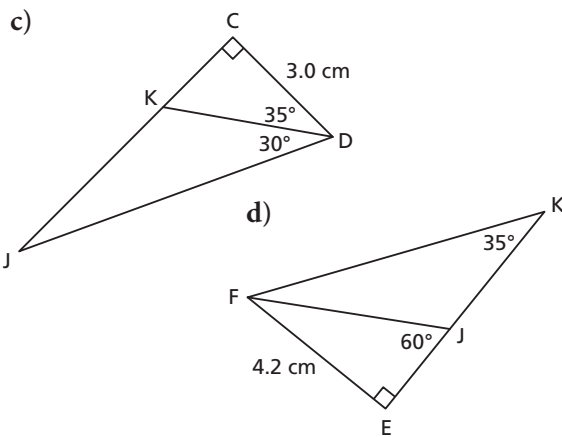
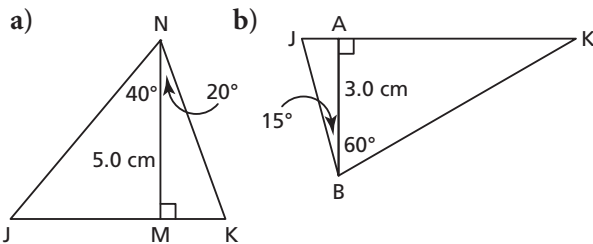

4. In each quadrilateral, calculate the length of GH to the nearest tenth of a centimetre.

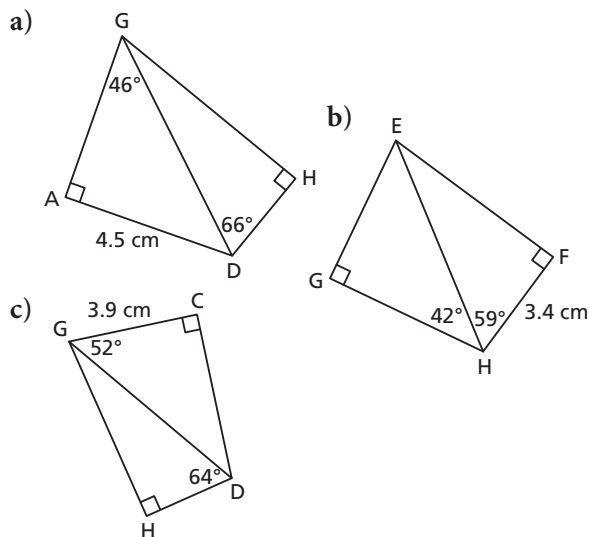

### B

5. In each diagram, calculate the measure of each  $\angle XYZ$  to the nearest tenth of a degree.

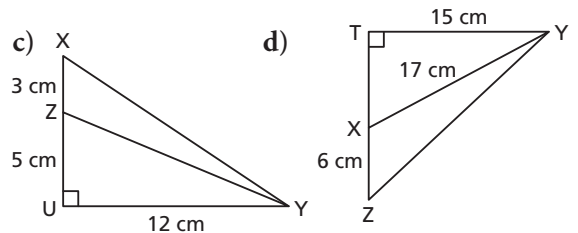
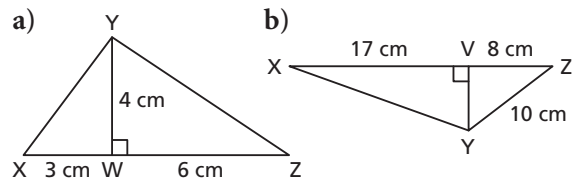

6. Two trees are 80 m apart. From a point halfway between the trees, the angles of elevation of the tops of the trees are measured. What is the height of each tree to the nearest metre?

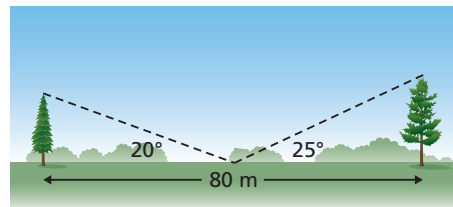

7. At the Muttart Conservatory, the arid pyramid has 4 congruent triangular faces. The base of each face has length 19.5 m and the slant height of the pyramid is 20.5 m. What is the measure of each of the three angles in the face? Give the measures to the nearest degree.

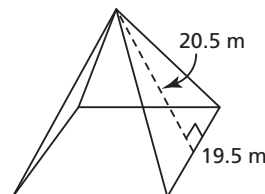

8. From a window on the second floor of her house, a student measured the angles of elevation and depression of the top and base of a nearby tree. The student knows that she made the measurements 16 ft. above the ground.

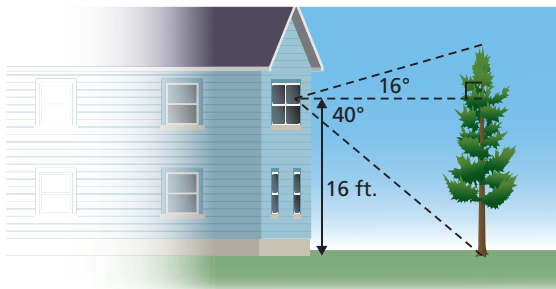

- a) What is the horizontal distance between the student and the tree?  
 b) How tall is the tree?  
 Give the measures to the nearest foot.
9. Two office towers are 50 m apart. From the top of the shorter tower, the angle of depression of the base of the taller tower is  $35^\circ$ . The angle of elevation of the top of this tower is  $25^\circ$ . Determine the height of each tower to the nearest metre.

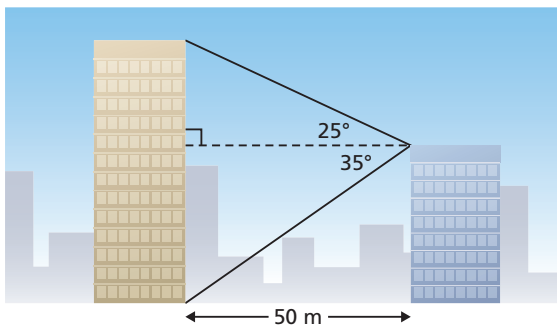

10. A rectangle has dimensions 5.5 cm by 2.8 cm. Determine the measures of the angles at the point where the diagonals intersect. What strategy did you use? Could you have determined the angle measures a different way? Explain.

11. A student wanted to know the distance between two particular carvings on a spirit pole. She measured the angle of elevation of each carving 15.0 m from the base of the pole. The student drew the sketch below. What is the distance between the carvings to the nearest tenth of a metre?

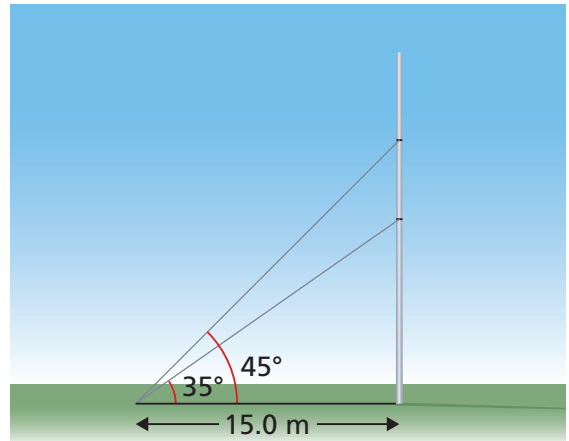

12. The Legislative Building in Wascana Park, Regina, has a domed tower at its centre.



Janelle stood due south of the tower, 40 m from a point directly beneath the dome, and measured the angle of elevation of the top of the dome as  $53^\circ$ . Troy stood due east of the tower and measured the angle of elevation of the top of the dome as  $61^\circ$ .

- a) How high is the top of the dome?  
 b) How far is Troy from a point directly beneath the dome?  
 c) How far apart are Janelle and Troy?  
 Give the measures to the nearest metre.

13. A communications tower has many guy wires supporting it. Two of these guy wires are 10.0 m and 8.0 m long. They are attached at the same point on the ground. The longer wire has an angle of inclination of  $60^\circ$ .

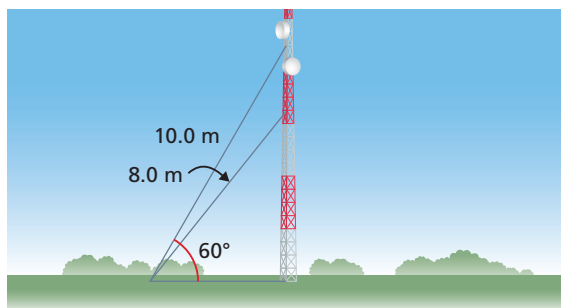

- How far from the base of the tower are the wires attached on the ground?
  - What is the angle of inclination of the shorter guy wire?
  - How far apart are the points where the guy wires are attached to the tower?
- Give the measures to the nearest tenth.

14. A surveyor drew the sketch below to show the measurements he took to determine the width and depth of a gorge.

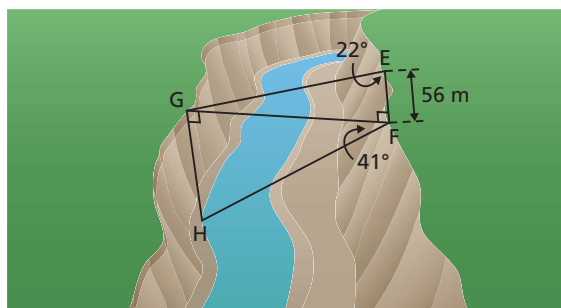

- Determine the width, GF, of the gorge.
  - Determine the depth, GH, of the gorge.
- Give the measures to the nearest metre.
15. A surveyor wants to determine the height of a cliff on the other side of the river from where she is standing. The surveyor cannot cross the river. She has a clinometer and a measuring tape. Describe how she can calculate the height of the cliff.

16. The Gastown Steam clock in Vancouver has been chiming since 1977. From a point on the ground, Connor measured the angle of elevation of the top of the clock tower as  $59.5^\circ$ . Monique was 3.5 m from Connor. The line joining them formed a right angle with the line joining Connor and the base of the tower. The angle between Monique's lines of sight to Connor and to the base of the tower was  $40.6^\circ$ .
- Sketch a diagram.
  - Determine the height of the tower to the nearest tenth of a metre.



### C

17. In the kite below, the shorter diagonal is 6.8 cm long.
- Determine the measures of the four angles of the kite to the nearest tenth of a degree.
  - Determine the length of the longer diagonal to the nearest millimetre.

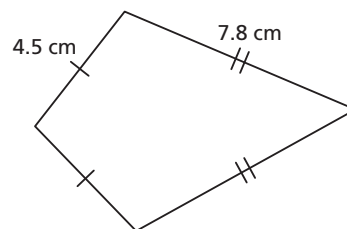

18. At the Muttart Conservatory, the tropical pyramid has 4 congruent triangular faces. The base of each face has length 25.7 m and the slant height of the pyramid is 27.2 m.
- Sketch and label the pyramid.
  - What is the height of the pyramid to the nearest tenth of a metre?

19. a) What is the length of the body diagonal in this rectangular prism?  
 b) What is the measure of  $\angle AFH$ , the angle between the body diagonal and a diagonal of the base of the prism?

Give the measures to the nearest tenth.

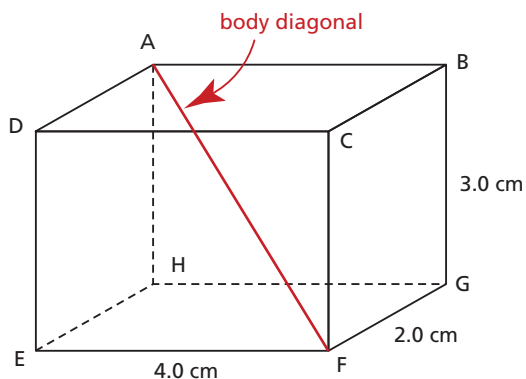

20. A communications tower is supported by guy wires. One guy wire is anchored at a point that is 8.9 m from the base of the tower and has an angle of inclination of  $36^\circ$ . From this point, the angle of elevation of the top of the tower is  $59^\circ$ . How far from the top of the tower is the guy wire attached to the tower?

21. A geodesic dome is constructed by bolting together many pentagonal pyramids. Each triangular face of a pyramid is formed with two struts, each 54 in. long, and one strut that is 60 in. long. Determine the height of one of these pyramids.

## Reflect

Summarize the different steps used to solve right triangle problems.



## THE WORLD OF MATH

### Historical Moment: Claudius Ptolemy

Claudius Ptolemy, who died in 161 CE, was a mathematician, an astronomer, and a geographer. He lived in Alexandria in Roman Egypt, and wrote in Greek. As part of his interest in astronomy, he extended the tables of trigonometric ratios started by Hipparchus of Bythnia (190 – 120 BCE) and studied triangles. Ptolemy's first major work, the *Almagest*, is the only ancient comprehensive material on astronomy that survives today. His other major works were *Geographia*, *Harmonics*, and *Optics*.



# STUDY GUIDE

## CONCEPT SUMMARY

### Big Ideas

In a right triangle:

- The ratio of any two sides remains constant if the triangle is enlarged or reduced.
- You can use the ratio of the lengths of two sides to determine the measure of one of the acute angles.
- You can use the length of one side and the measure of an acute angle to determine the length of another side of the triangle.
- You can use the primary trigonometric ratios to solve problems that can be represented using right triangles.

### Applying the Big Ideas

This means that:

- The size of the triangle does not affect the value of any trigonometric ratio of an acute angle in the triangle.
- If the tangent ratio, sine ratio, or cosine ratio of an angle is known, the related inverse operation —  $\tan^{-1}$ ,  $\sin^{-1}$ , or  $\cos^{-1}$  — on a scientific calculator can be used to determine the measure of the angle.
- You can use the definition of the tangent ratio, sine ratio, or cosine ratio to create an equation. You can then solve this equation to determine the unknown side length.
- You can solve problems that involve more than one right triangle by applying the trigonometric ratios to one triangle at a time.

### Reflect on the Chapter

- How were the properties of similar triangles used to establish the meaning of the sine, cosine, and tangent ratios?
- When you used the trigonometric ratios to solve a problem, why was it important to be able to sketch the situation to show the given information?

## SKILLS SUMMARY

### Skill

### Description

### Example

Calculate a trigonometric ratio.

[2.1, 2.4]

$$\tan A = \frac{\text{opposite}}{\text{adjacent}}$$

$$\sin A = \frac{\text{opposite}}{\text{hypotenuse}}$$

$$\cos A = \frac{\text{adjacent}}{\text{hypotenuse}}$$

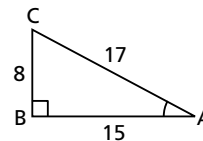

$$\tan A = \frac{\text{opposite}}{\text{adjacent}}$$

$$\tan A = \frac{BC}{BA}$$

$$\tan A = \frac{8}{15}, \text{ or } 0.5\bar{3}$$

Determine the measure of an angle.

[2.1, 2.4]

In right  $\triangle ABC$ , to determine the measure of acute  $\angle A$  when you are given:

- the length of the adjacent leg, AB
- the length of the hypotenuse, AC

1. Determine  $\cos A$  using the given lengths.
2. Use  $\cos^{-1}$  on a scientific calculator to determine the measure of  $\angle A$ .

In  $\triangle ABC$  above,

$$\cos A = \frac{\text{adjacent}}{\text{hypotenuse}}$$

$$\cos A = \frac{AB}{AC}$$

$$\cos A = \frac{15}{17}$$

$$\angle A \doteq 28^\circ$$

Determine the length of a side.

[2.2, 2.3, 2.5]

In right  $\triangle PQR$ , to determine the length of the hypotenuse QP when you are given:

- the measure of  $\angle P$  and
- the length of the leg QR

1. Identify the trigonometric ratio to use, then write an equation.
2. Substitute the known values.
3. Solve the equation for the unknown length.

Then, if you need to determine the length of the leg PR:

4. Use a trigonometric ratio, or use the Pythagorean Theorem.

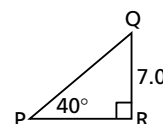

$$\sin P = \frac{\text{opposite}}{\text{hypotenuse}}$$

$$\sin P = \frac{QR}{QP}$$

$$\sin 40^\circ = \frac{7}{QP}$$

$$QP = \frac{7}{\sin 40^\circ}$$

$$QP \doteq 10.9$$



# REVIEW

## 2.1

1. Determine each indicated angle to the nearest degree.

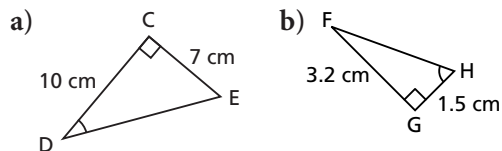

2. a) Is  $\tan 20^\circ$  greater than or less than 1?  
 b) Is  $\tan 70^\circ$  greater than or less than 1?  
 c) How could you answer parts a and b if you did not have a calculator? Sketch a right triangle to illustrate your answer.
3. A road rises 15 m for each 150 m of horizontal distance. What is the angle of inclination of the road to the nearest degree?
4. Sketch a triangle to show that  $\tan 45^\circ = 1$ . Describe the triangle.

## 2.2

5. a) Determine the length of each indicated side to the nearest tenth of a centimetre.

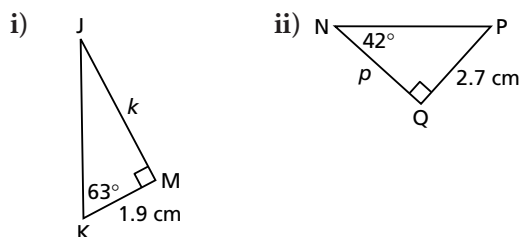

- b) Use the Pythagorean Theorem to determine the length of the hypotenuse of each triangle in part a. What other strategy could you have used to determine each length?
6. At a point 100 m from the base of the Eiffel tower, the angle of elevation of the top of the tower is  $73^\circ$ . How tall is the tower to the nearest metre?

7. The shorter side of a rectangle is 5.7 cm. The angle between this side and a diagonal is  $64^\circ$ .
- a) Determine the length of the rectangle.  
 b) Determine the length of a diagonal.  
 State the answers to the nearest tenth of a centimetre.

8. A tree casts a shadow that is 31.5 m long when the angle between the sun's rays and the ground is  $29^\circ$ . What is the height of the tree to the nearest tenth of a metre?

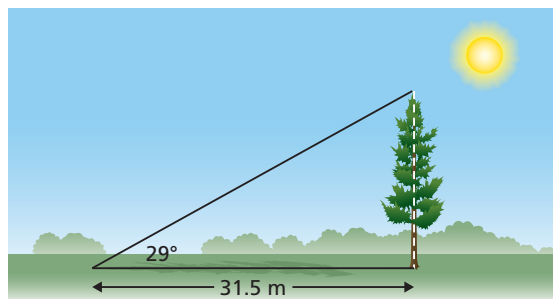

9. Aidan knows that the observation deck on the Vancouver Lookout is 130 m above the ground. He measures the angle between the ground and his line of sight to the observation deck as  $77^\circ$ . How far is Aidan from the base of the Lookout to the nearest metre?



## 2.3

10. Use your drinking-straw clinometer to measure the height of your gymnasium to the nearest tenth of a metre. Explain your strategy. Include a sketch that shows all the measurements you made or calculated.

## 2.4

11. Determine the measure of each indicated angle to the nearest degree. Which trigonometric ratio did you use each time? Explain why.

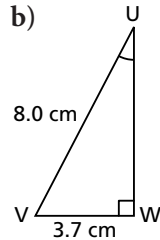
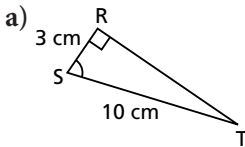

12. Sketch and label right  $\triangle BCD$  with  $BC = 5$  cm,  $CD = 12$  cm, and  $BD = 13$  cm.

a) What is the value of each ratio?

- i)  $\sin D$                       ii)  $\sin B$   
 iii)  $\cos B$                     iv)  $\cos D$

b) How are the ratios in part a related?

Explain why this relationship occurs.

13. During a storm, a 10.0-m telephone pole was blown off its vertical position. The top of the pole was then 9 m above the ground. What was the angle of inclination of the pole to the nearest tenth of a degree?

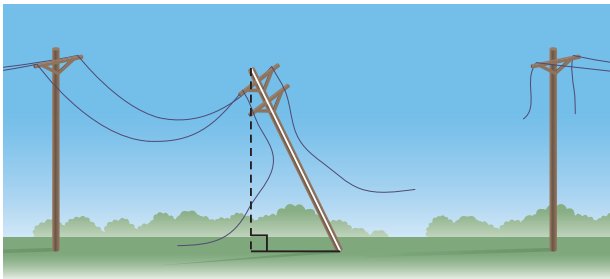

14. Determine the measure of  $\angle C$  in this trapezoid. Give your answer to the nearest tenth of a degree. Describe your strategy.

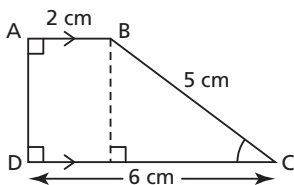

## 2.5

15. Determine the length of each indicated side to the nearest tenth of a centimetre. Which trigonometric ratio did you use each time? Explain why.

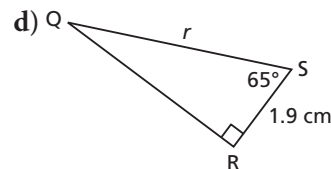
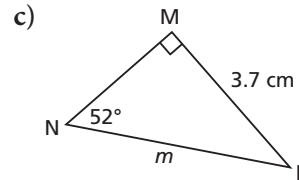
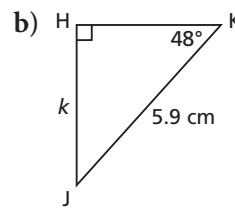
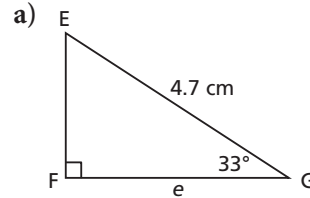

16. A ship is sailing off the west shore of Hudson Bay. At a certain point, the ship is 4.5 km due east of the town of Arviat. The ship then sails due north until the angle between the path of the ship and the line of sight to Arviat is  $48.5^\circ$ . How far is the ship from Arviat? State the answer to the nearest tenth of a kilometre.

17. Determine the dimensions of this rectangle to the nearest tenth of a centimetre.

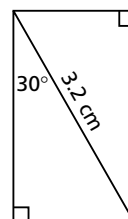

**2.6**

18. Solve each right triangle. State the measures to the nearest tenth.

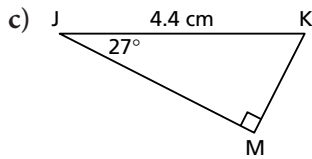
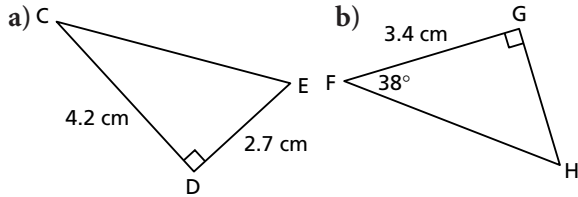

19. In Italy, the Leaning Tower of Pisa currently leans 13 ft. off the vertical. The tower is 183 ft. tall. What is its angle of inclination to the nearest tenth of a degree?



20. Determine the perimeter and area of each shape. Give the measures to the nearest tenth.

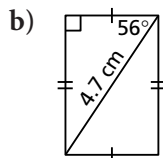
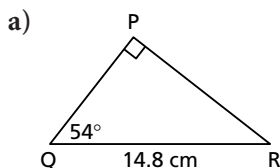

21. Cars are parked at an angle to the street. The diagram shows a parking space.

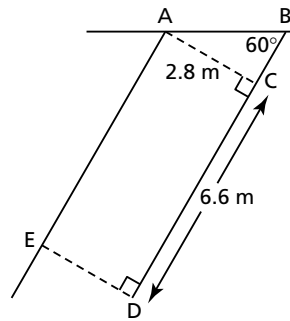

a) What is the length, AB?  
 b) What is the length, BD?  
 Give the measures to the nearest tenth of a metre.

**2.7**

22. In the diagram below, determine each measure.

a)  $\angle KJH$       b) HK      c)  $\angle HKJ$   
 Give the measures to the nearest tenth.

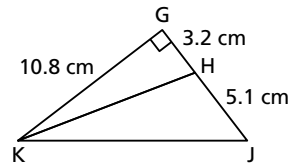

23. A fire ranger is at the top of a 90-ft. observation tower. She observes smoke due east at an angle of depression of  $5^\circ$  and due west at an angle of depression of  $4^\circ$ . How far apart are the fires to the nearest foot? The diagram is *not* drawn to scale.

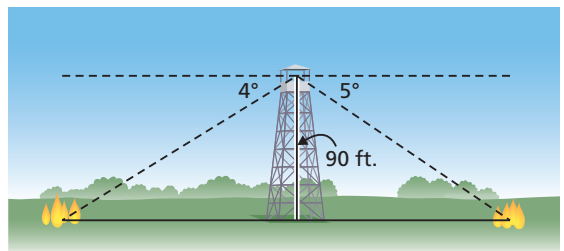

# PRACTICE TEST

For questions 1 and 2, choose the correct answer: A, B, C, or D

1. For  $\triangle PQR$ , how many of these statements are true?

$$\tan Q = \frac{3}{4}$$

$$\sin P = \frac{3}{5}$$

$$\sin Q = \frac{3}{5}$$

$$\tan P = \frac{4}{3}$$

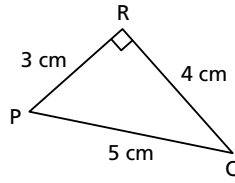

- A. All are true.    B. 3 are true.    C. 2 are true.    D. 1 is true.
2. In right  $\triangle PQR$ , with  $\angle Q = 90^\circ$ , which statement is true?  
As  $\angle P$  increases:
- A.  $\tan P$  decreases                      B.  $\sin P$  decreases  
C.  $\cos P$  decreases                      D.  $\cos P$  increases
3. Triangle ABC is similar to  $\triangle XYZ$  and  $\angle A = \angle X = 90^\circ$ .  
Use a diagram to explain why  $\sin B = \sin Y$ .
4. In right  $\triangle DEF$ ,  $\angle E = 90^\circ$ ,  $\angle F = 63^\circ$ , and  $DF = 7.8$  cm. Solve this triangle.  
State the measures to the nearest tenth.
5. A ramp is used to load a snowmobile onto the back of a pickup truck. The truck bed is 1.3 m above the ground. For safety, the angle of inclination of the ramp should be less than  $40^\circ$ . What is the shortest possible length of the ramp to the nearest centimetre? Explain why.

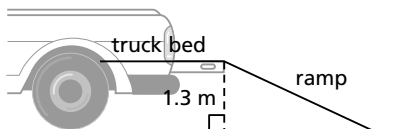

6. A student uses a clinometer to measure the angle of elevation of a sign that marks the point on a tower that is 50 m above the ground. The angle of elevation is  $37^\circ$  and the student holds the clinometer 1.5 m above the ground. She then measures the angle of elevation of the top of the tower as  $49^\circ$ . Determine the height of the tower to the nearest tenth of a metre. The diagram is *not* drawn to scale.

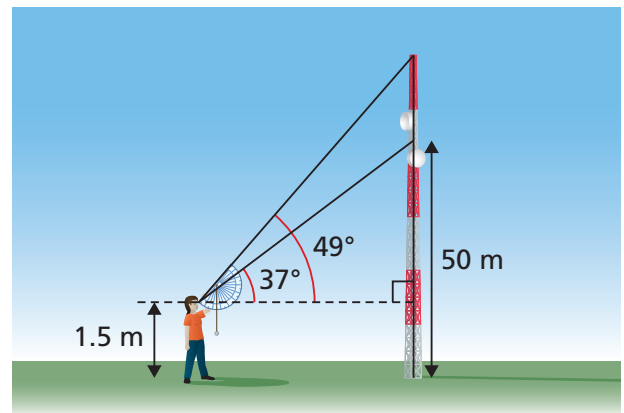

# Ramp It Up!

New public buildings should be accessible by all, and if entry involves steps, an access ramp must be provided. Older buildings are often retro-fitted with ramps to provide easy access.



## PART A: DESIGN

Choose a doorway to your school or to a building in your neighbourhood for which a wheelchair ramp could be constructed.

- Measure or use trigonometry to determine the height of the doorway above the ground.

Most building codes require the slope of an access ramp to be no greater than 1:12; that is, for a rise of 1 cm, the ramp must be 12 cm long. Slopes of 1:15 or 1:20 are preferable. A ramp should be at least 915 mm wide.

- Determine the minimum length of ramp required.
- Draw a labelled diagram of your ramp that shows all required lengths and angle measures.

## PART B: COST ESTIMATES

A ramp may be constructed from wood or concrete.

- Research, then estimate, the cost of constructing your ramp using lumber from your local supplier. Assume that the ramp surface will be strandboard, or particleboard, or plywood. Give details of all the conversions between systems of measure.
- Research, then estimate, the cost of constructing your ramp using concrete.

Outdoor ramps can become slippery in wet or cold weather, so your ramp surface should have a non-slip coating.

- Research, then estimate the cost of covering the ramp surface with non-slip paint or other material.



## PROJECT PRESENTATION

Your completed project should include:

- Your diagram, with calculations and explanations to support your design.
- Cost estimates for the construction in both wood and concrete, with all supporting calculations.

## EXTENSION

Access ramps may have level landings with an area of at least  $1.525 \text{ m}^2$ . These landings are often at the top and bottom, but a long ramp may have a landing as a rest spot. Because of space consideration, long ramps may change direction. Ramps that rise more than 15 cm or have a horizontal distance of more than 1.83 m require a handrail.

- Design and cost your ramp to meet the requirements above with a landing at the top and bottom.

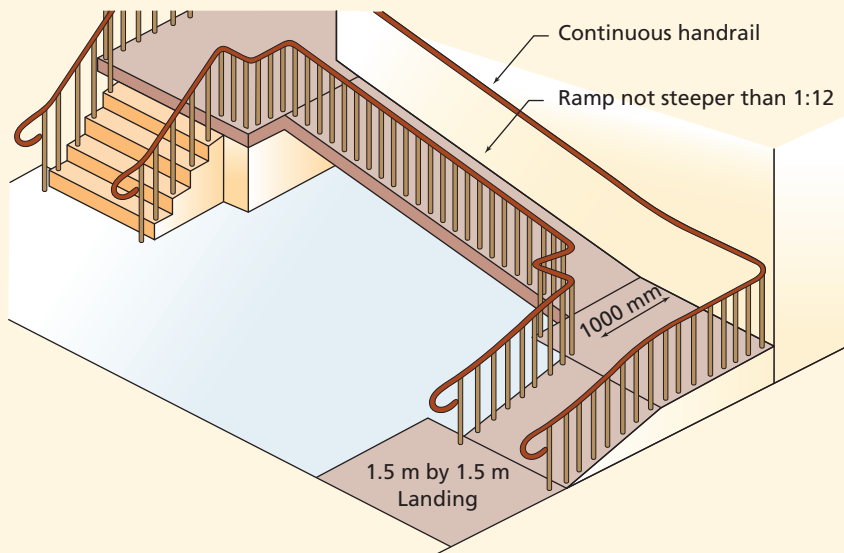

1

- Andrea is constructing a pen for her dog. The perimeter of the pen is 70 ft.
  - What is the perimeter of the pen in yards and feet?
  - The fencing material is sold by the yard. It costs \$2.49/yd. What will be the cost of this material before taxes?
- A map of Alberta has a scale of 1:4 250 000. The map distance between Edmonton and Calgary is 6.5 cm. What is the distance between the two cities to the nearest kilometre?
- Describe how you would determine the radius of a cylindrical pipe in both imperial units and SI units.
- Convert each measurement.
  - 9 yd. to the nearest centimetre
  - 11 000 000 in. to the nearest metre
  - 5 km to the nearest mile
  - 160 cm to feet and the nearest inch
- On the Alex Fraser Bridge in Delta, B.C., the maximum height of the road above the Fraser River is 154 m. On the Tacoma Narrows Bridge in Tacoma, Washington, the maximum height of the road above The Narrows is 510 ft. Which road is higher above the water? How much higher is it?

- Determine the surface area of each object to the nearest square unit.

a) regular tetrahedron

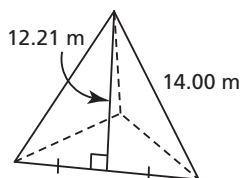

b) right cone

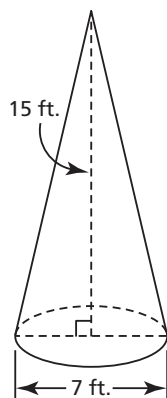

- Determine the volume of the cone in question 6, to the nearest cubic unit.
- The diameter of the base of a right cone is 12 yd. and the volume of the cone is 224 cubic yards. Describe how to calculate the height of the cone to the nearest yard.
- One right square pyramid has base side length 10 cm and height 8 cm. Another right square pyramid has base side length 8 cm and height 13 cm. Does the pyramid with the greater volume also have the greater surface area? Justify your answer.
- A hemisphere has radius 20 in. A sphere has radius 17 in.
  - Which object has the greater surface area? How much greater is it, to the nearest square inch?
  - Which object has the greater volume? How much greater is it, to the nearest cubic inch?
- This composite object is a rectangular pyramid on top of a rectangular prism. Determine the surface area and volume of the composite object to the nearest unit.

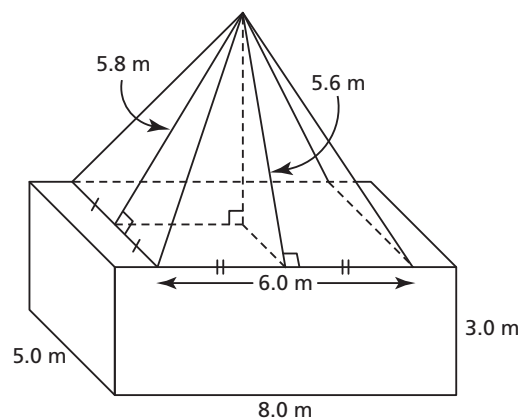

- The height of a right square pyramid is 40 in., and the side length of the base is 48 in. Determine the lateral area of the pyramid to the nearest square inch.
- The base of a hemisphere has a circumference of 30.5 mm. Determine the surface area and volume of the hemisphere to the nearest tenth of a millimetre.

14. Determine the angle of inclination of each line AB to the nearest tenth of a degree.

a)

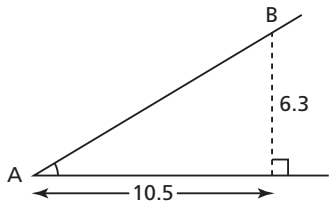

b)

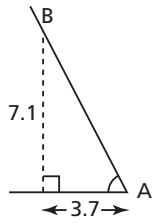

15. Barry is collecting data on the heights of trees. He measures a horizontal distance of 20 yd. from the base of a tree. Barry lies on the ground at this point and uses a clinometer to measure the angle of elevation of the top of the tree as  $52^\circ$ . Determine the height of the tree to the nearest yard.

16. Jay Cochrane walked a tightrope between the Niagara Fallsview Hotel and the Skylon Tower in Niagara Falls. He began at the hotel. The rope sloped upward and the average angle between the rope and the horizontal was  $6.4^\circ$ . Jay walked a horizontal distance of 1788 ft. To the nearest foot, determine the vertical distance he travelled.

17. Determine the measure of each indicated angle to the nearest tenth of a degree.

a)

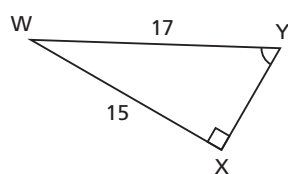

b)



18. A 12-ft. ladder leans against a wall. The base of the ladder is  $4\frac{1}{2}$  ft. from the wall. To the nearest degree, what is the measure of the angle between the ladder and the wall?

19. A basketball court is rectangular with diagonal length approximately 106 ft. The angle between a diagonal and a longer side is  $28^\circ$ . Determine the dimensions of the basketball court to the nearest foot.

20. Solve each right triangle. Write the measures to the nearest tenth.

a)

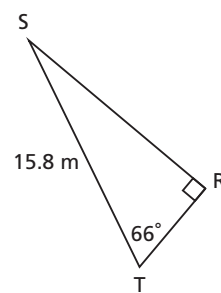

b)

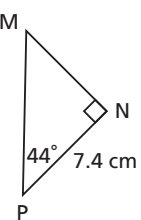

21. A helicopter is 15 km due east of its base when it receives a call to pick up a stranded snowboarder. The person is on a mountain 9 km due south of the helicopter's present location. When the helicopter picks up the snowboarder, what is the measure of the angle between the path the helicopter took flying south and the path it will take to fly directly to its base? Write the angle to the nearest degree.

22. Determine the length of each indicated side and the measures of all the angles in this diagram. Write the measures to the nearest tenth.

